



CARE & MAINTENANCE MANUAL

INTRODUCTION

This Care & Maintenance guide was prepared to help you understand the safe, proper use and operation of your Unit, the servicing and maintenance of component parts, and includes an explanation of your warranty protection. If you are a newcomer to camping with a trailer or caravan, you may appreciate the suggestions and information to be found in this manual. This information is provided to help you best use & enjoy your Unit.

Throughout this manual Lumberjack Camper Trailers & Lumberjack Camper Trailer Units may be referred to as 'Lumberjack', 'Lumberjack Unit' or 'Unit' for abbreviation purposes.

Used within recommended guidelines and procedures, your Lumberjack will provide you with years and many happy kilometres of trouble-free travel. Your first Service (1000kms or 3 months) after an initial running-in period is the ideal time to have any minor adjustments to components be made and for us to answer any questions you may have.

On completion of your warranty period we recommend a second Service (10,000km or 12 months). From then on, we then recommend your Unit has an annual service.

DISCLAIMER

The contents of this manual (including but not limited to information about Lumberjack Camper Trailers products and services and operating recommendations) is provided for general information purposes and is a guide only. We endeavour to be as accurate as possible in order to reflect information available at the time of distribution.

Every effort has been made in the production of this manual to provide accurate information and to encourage Lumberjack customers to use safe working practices in relation to the operation for Lumberjack products. However, you must make and rely on your own assessment of your particular situation to determine the suitability and usefulness of this information.

Accordingly, Lumberjack makes no representations, warranties or guaranties, either express or implied, regarding the suitability of usefulness of this information.

Products are constantly being improved and we seek to upgrade our components and parts accordingly. If the equipment in your Unit differs from some descriptions contained within this manual, disregard the instructions not relevant to your Unit and follow those which do.

Lumberjack Camper Trailers accepts no liability for any loss, damage, claim or expense suffered by you arising from your use of or reliance on the information provided in this manual.

Keep this Owner's Manual in your Unit for handy reference. It will help you get to know your Lumberjack and how it operates. Your Lumberjack represents a considerable personal investment. Protect that investment and retain its value by a planned program of operation, routine maintenance, and attention to safety inspections.

When questions arise that are not adequately covered by this manual or the manufacturer's instructions, consult Lumberjack directly.

Table of Contents

INTRODUCTION	2
DISCLAIMER	2
A. CUSTOMER RELATIONS & HANDOVER PROCEDURES	5
AT TIME OF SALE	5
HANDOVER.....	5
VEHICLE PREPARATION FOR HANDOVER	5
B. RESOURCES	6
USER GUIDES	6
FACEBOOK	6
YOUTUBE	6
WARRANTY CLAIMS.....	7
<i>Externally Supplied Equipment</i>	7
FACTORY SECONDS & DEMO MODELS	8
INSURANCE.....	8
C. GETTING STARTED	9
HIGHLY RECCOMENDED TIPS	9
PACKING TIPS.....	9
BEFORE TOWING	9
<i>Pre Trip Checklist</i>	10
VEHICLE IDENTIFICATION PLATE	11
BEFORE YOU LEAVE CAMP	11
<i>Daily Checks</i>	11
ON THE ROAD	12
TURNING & OVERTAKING	12
OFF ROAD DRIVING.....	12
CONNECTION PLUGS	14
RECOVERING YOUR UNIT	15
REVERSING	15
SAFETY DURING AND EMERGENCY STOP	15
BAD WEATHER.....	15
SECURING YOUR UNIT	15
D. SET UP – OPERATION	16
<i>SETTING UP - THE BASICS</i>	16
<i>Levelling your Unit</i>	16
<i>Kitchen Unit</i>	16
<i>Main Control Panels</i>	17
<i>Control Panel Components</i>	18
ACTUATORS.....	20
<i>Actuator Control Panels</i>	20
<i>Actuator Remotes</i>	21
E. PACKING DOWN THE UNIT – CAMPER TRAILERS	22
<i>Winch Closing</i>	22
<i>Actuator Closing</i>	22
F. CARE & MAINTENANCE	23
SECURING YOUR UNIT	23
CAMPER BODY MAINTENANCE.....	23
FUSES.....	23
STABILISER LEGS	23
JOCKEY WHEEL USER GUIDE	25
<i>Maintenance</i>	25
BREAK AWAY USER GUIDE	26
CARGO RACK USER GUIDE	27
CHANGING WHEELS.....	29
CHANGING WHEEL WARNING	29
BEARINGS & SEALS.....	30
<i>Wheel Bearings</i>	30
<i>Wheel Bearing Seals</i>	30
<i>Seals</i>	30

BATTERY MAINTENANCE	31
<i>Charging your batteries</i>	31
<i>Charger Types</i>	31
<i>Care During storage</i>	32
<i>Checking the battery state of charge</i>	32
<i>Checking individual battery charge state</i>	32
<i>External Maintenance</i>	32
<i>Century Official Condition Check</i>	32
<i>Why do batteries fail?</i>	33
<i>Emergencies</i>	33
<i>Battery Warranty (Century Branded Batteries)</i>	33
GAS BOTTLE AND REGULATOR	34
<i>Gas Warning</i>	34
WATER TANKS	34
<i>General cleaning</i>	34
<i>Mould</i>	34
<i>Storage</i>	34
AIR CONDITIONERS	34
BRAKE ADJUSTMENT	35
<i>Brake Linings</i>	35
<i>Wheel Nuts</i>	35
240v ELECTRICAL SYSTEM	36
<i>How to use:</i>	36
CANVAS	38
<i>Tent</i>	38
<i>Seasoning</i>	38
<i>Storage Tips</i>	38
CLEANING	39
<i>Camper Trailer Body</i>	39
<i>Tyre Rims</i>	39
<i>Aluminium</i>	39
<i>Canvas Care</i>	39
<i>Awnings</i>	39
<i>Cushions & Mattresses</i>	39
<i>Floors</i>	40
<i>Seating Base</i>	40
<i>Carpet (Exterior Drawers)</i>	40
<i>Kitchen Unit (Stainless Steel)</i>	40
<i>Solar Panels (if applicable)</i>	40
GENERAL STORAGE	41
G. SERVICING	42
LUMBERJACK SERVICING SCHEDULE	43
H. TROUBLE SHOOTING	44
GAS	44
WATER TANKS	44
ELECTRICAL	45
ACTUATORS	46
BATTERIES	48
I. NOTES	50

A. Customer Relations & Handover Procedures

AT TIME OF SALE

We will strive to ensure that throughout the order process you will be kept informed of your trailer building and delivery timeframe.

If we are unable to delivery your trailer by the estimated delivery date, you will be informed along the way.

Please understand the estimates are given as accurate at the time of sale and as such are ONLY estimates.

Please ensure you take the time to read this Care & Maintenance Guide as well as your User guide. Also visit our YouTube channel: www.youtube.com/c/LumberjackCamperTrailers to watch our various informational videos and to best inform you all about your Unit before collection.

HANDOVER

Handover usually takes around 1 hour. We conduct handovers during weekdays.

Our handover is limited to an overview of the trailer's usage.

We encourage you to ask questions during handover.

There is a lot of information to take in on the day.

Please take time to watch our YouTube videos beforehand and read through this user guide before you collect your trailer.

VEHICLE PREPARATION FOR HANDOVER

Before your handover please ensure the vehicle you are using to tow your Unit is capable of doing so safely by checking its towing capacity rating against the Unit your will be towing.

By law, electric brakes must be fitted to your towing vehicle before you collect your trailer. Please ensure that these are fitted.

If not you will not be able to take collection of your Unit until they have been fitted.

We will attach a towing coupling to your vehicle to tow your trailer with the off road hitch.

Please ensure that you have removed only your tow ball beforehand.

Be aware that they can be very difficult to remove.

B. Resources

USER GUIDES

Please visit our webpage www.lumberjackcampertrailers.com.au/guides to download your user guide. This page also has downloadable pole plans and other valuable resources for you.

Your password to download the guides is: ilovemylumberjack

FACEBOOK

We can't wait to see some great pictures of your adventures you will have. You are invited to post them on our Facebook page.

www.facebook.com/lumberjackcampertrailers/

If you have not already, please visit our designated Facebook Page for Lumberjack Camper Trailers Owners: Lumberjack Family Page. Here you can share your adventures with other Lumberjack owners, share stories and ask questions about your trailer. You'll be asked for your trailer VIN to join.

YOUTUBE

We have loads of helpful videos on our YouTube channel. Please take a moment to visit our channel for some handy hints and video guides.

www.youtube.com/c/LumberjackCamperTrailers

WARRANTY CLAIMS

If you encounter any issues with your trailer, please call us on ph. 1300 30 40 45. Your salesperson will firstly assist you with some trouble shooting. If your issue persists, we have a simple claim procedure to follow that our Customer Care team will guide you through.

With your handover kit you will have been given a copy of the Lumberjack Camper Trailers warranty, please take the time to review this as it contains important information.

Please note that no individual (including any sales persons or representatives of Lumberjack) is authorised to make any representation or warranty statements regarding Lumberjack or its products, except to refer the purchaser to this warranty information. Any representation contrary to the provided documentation is invalid whether expressed or implied verbally or in writing.

Should you need to submit a warranty enquiry to us please go to the following webpage: lumberjackcampertrailers.com.au/warranty-enquiry/. This page can be found through the main menu under the 'About Us' tab.

Once on this page you will be provided with some information regarding the warranty enquiry process, please read this before proceeding to submit your enquiry.

All warranty enquiries MUST be submitted through our website using the warranty claim form.

Please Note:

- *When submitting an enquiry make sure to include images as they assist greatly in the review process.*
- *Warranty enquiries may take 3-5 days to go through the processing & reviewing phase.*
- *Under no circumstances will re-imburement be made for work done through unauthorised establishments without prior written consent from Lumberjack.*
- *Lumberjack reserves the right to make product changes and improvements without imposing any obligation on itself for warranty purposes to install the same products or components originally supplied, and where it is appropriate to do so shall install or supply with current product or component.*

Externally Supplied Equipment

Some of the equipment supplied with your Unit is not manufactured or imported by Lumberjack and is separately warranted by the manufacturer or importer. This may also be the case for products or upgraded options that you have chosen.

Some of the fittings & equipment which may be separately warranted could include:

- Jockey Wheels
- Batteries
- Actuators
- Shock absorbers
- Cooktops (Caravans)
- Hot Water Units (Caravans)
- Air Conditioners (Caravans)
- Solar Panels (Caravans)
- Firefly products

Lumberjack assumes no responsibility or liability for defects in workmanship or operation of separately warranted products.

Certain separately warranted products will not be serviced, repaired or replaced by Lumberjack unless required by law or expressed in writing. You should contact the manufacturer or importer of the product and make your claim in accordance with their warranty statement.

Please note that the length of warranty periods and their terms may vary depending on the item.

For further information please feel free to give us a call us on 1300 30 40 45.

FACTORY SECONDS & DEMO MODELS

From time to time, Lumberjack may offer items deemed to be "Factory seconds" or "Ex-demonstration". Any items sold under the above categories are sold on an 'as is' basis.

There are no warranties, refunds, credits, exchanges or similar associated with such items. In the sale of such items, Lumberjack will attempt to provide all relevant information regarding the item, including faults, defects or similar & will record these on the contract of sale, however there may be instances where minor defects or imperfections have been overlooked. This is PURLEY UNINTENTIONAL and in no way alters the nature of the sale.

Due to the nature of such items, i.e. being "Ex-demonstration" or 'factory seconds', it is reasonable to expect that some imperfections or flaws may exist even where it is not initially apparent. By purchasing such an item, you agree to this statement in full & accept that there are no warranties implied or expressed & Lumberjack is under no obligation to repair or amend these imperfections unless otherwise stated in writing.

Warranties are not transferable under any circumstances. Similarly, if an item is sold to a third party by the original purchaser, then all warranties become null and void, and the original purchaser shall make no claims or be eligible for any claims on behalf of the new owner.

If you have any further questions relating to warranties or are unsure about any aspect of this section, please contact us on: 1300 30 40 45.

INSURANCE

As you insure your car, it is important that you also protect yourself and others with insurance coverage for personal liability, theft, collision etc. If you are yet to purchase insurance for your Unit, your salesperson can assist you in obtaining specialised insurance.

Please note that exceeding the load limit of your Unit, and/or towing vehicle, above the manufacturer's recommended maximum weight (noted on the Vin plate) may invalidate your insurance cover should an accident occur.

C. Getting Started

HIGHLY RECOMMENDED TIPS

There are a few extra items which we recommend adding to your camping kit to further enhance your camping experience, the items listed are not necessary, just recommendations Lumberjack have:

- **Padlocks** – To secure the lid of your camper closed during travel & when not in use.
- **Small non coloured candle** – Believe it or not but candle wax can be used to help waterproof seams on the canvas in emergency situations. All you need to do is rub the non-lit candle against the section of canvas seam.
- **Recovery Equipment** – (E.g. Recovery straps) Recommended if going off road or on terrain where bogging could occur.
- **Reflective Road Triangles** – For use in emergency situations if you need to pull over on a road, they can be set out to warn oncoming drivers.
- **Level device** – Small levelling devices can be used to ensure your Unit is set up to be accurately level.
- **Anti-Slip matting** – If you keep some with you, it will always come in handy. (e.g. inside kitchen drawers or for your table etc.)
- **First Aid kit** – The absolute essential for every camping trip.
- **Silicon Lubricant Spray** – This is recommended for rubber seal maintenance.
- **Lanolin Lubricant (Fleece Grease)** - Great for maintenance use & ideal for use on all external bolts & joints to prevent rusting.
- **Levelling Blocks** – To assist with a quick & easy setup process.
- **Step Ladder** – Bringing one with you makes setting up your annex much simpler.

PACKING TIPS

When packing your trailer or caravan for a trip it is important to pack correctly, the way you pack your Unit can affect the way it will tow behinds your vehicle. The following are recommendations for packing your Unit in the best way:

- Ensure to evenly load the Unit, with equal weight distributed across the axle.
- Any heavy cooking equipment should be kept in lower storage compartments (preferable).
- Ensure no items can move around during traveling times as this can result in damages to both the item and your Unit.
- **NEVER** overload the Unit in a manner which causes the ball weight to exceed the vehicles towing capacity.
- Do not load the cargo rack with more than 200Kg of weight as it could lead to damages & excessive weight on the ball of the Unit.
- Each of the fridge slide drawers has a load rating of 100Kg MAX. The Storage drawers have a max load rating of 20Kg.
- When loading the cargo rack keep items centred to distribute weight evenly across the axle.

***IMPORTANT NOTE:** The rear winch support is designed for the winch ONLY. Do not load any bike carriers or other attachments on this winch support. Any damages caused as a result of ignoring this warning are not covered by the Lumberjack Warranty.*

BEFORE TOWING

Make sure you do not exceed the A.T.M weight of your Unit which is stated on your VIN plate or the allowed ball weight on your towing vehicle.

Please Note: If you do not know the ball weight of your Unit you can purchase a ball weight scale from an automotive specialty store (e.g. Autobarn, Super cheap auto etc.).

Important Note: If your Unit has been retro fitted with a cargo rack, you will need to take this into your load consideration as it weighs approx. 90Kg.

Ensure your tyres are in good condition and properly inflated to the correct pressure. Refer to your vehicle's VIN Plate for correct pressure for road driving. The pressure needs to be suitable for the environment where you are taking your Unit, if going off road please refer to the recommended pressures listed in the 'Off Road Driving' section of this manual.

Pre Trip Checklist

Are you ready to go on your trip? Have you checked all of the following? Preferably a couple of days before you are going to head off you need to review the following points:

- Gas bottles are sufficiently full & safe for use
- Fill water tanks if required
- Coupling is secured to towing tongue correctly
- Breakaway Unit is attached correctly
- Complete Wheel Condition Check
 - Nuts (sufficiently tightened & in good condition etc.)
 - Pressures (correct for your driving environment)
 - Bearings
 - Tyre Condition (no punctures & correct pressures for conditions)
 - Hubs behind each wheel
- Undercarriage Check (General inspection)
- Shock absorbers (all bolts in place & no leaks)
- All poles present
- All canvas pieces present
- Batteries are fully charged
- Tail lights & plug as well as Anderson connection is working correctly
- Lid latches firmly shut & pins in place
- Battery isolator off while driving & Anderson plug connected
- Toolbox door seals are in good condition & waterproof when closed (please refer to maintenance section for further instructions)
- Greased specified points on Unit required (Please refer to maintenance section for further instructions)
- Battery terminals secure
- Ball Weight Checked
- Unit does not exceed ATM on Vin plate

VEHICLE IDENTIFICATION PLATE

This Unit is fitted with a Vehicle Identification Plate (V.I.N. Plate) that shows the following information

MANUFACTURER

Manufacturer's Name

DATE OF MANUFACTURE

Date produced

GROSS TRAILER MASS kg

Maximum loaded weight on the tyres.

AGGREGATE TRAILER MASS kg

Maximum loaded total weight.

V.I.N. NUMBER

17 digit identification number.

WHEEL RIM SIZE/PROFILE

Dimension of rims fitted as standard.

TYRE SIZE

Dimension of tyres fitted as standard.

TYRE LOAD RATING

Individual load rating of tyres.

TYRE PRESSURE (COLD)

Recommended tyre pressures.

AXLE/AXLE GROUP LOAD CAPACITY

Maximum load capacity of axles.

TARE WEIGHT *

Unladen weight.

*Tare weight does not include retro fitted cargo racks as they are removable.

BEFORE YOU LEAVE CAMP

When on the road on during your holiday, there are some things you need to check each day you are on the road, these are important safety checks which must be done every day.

In extreme conditions or when traveling long distances some items will need checking multiple times a day. Items with this requirement will be marked **

Daily Checks

1. 12v Led internal and external lighting turned off
2. Gas bottle turned off when not in use
3. Stabilizer legs up
4. Fit and adjust towing mirrors if required
5. Annexe, poles, ropes and pegs stowed
6. External doors securely closed & locked
7. Main tent body zipped closed (including windows & doors)
8. Jockey wheel Raised
9. Raise step on hybrid models
10. Tyres: Check pressure and condition **
11. Wheel nuts **
12. Tail light plug and check all lights **
13. Attach chains & breakaway
14. Check all controls on electric brakes, listen for hum in drums
15. Lid latches firmly shut & pins in place**
16. External component bolts (polyblock mount, stone guard, gas & jerry can holders) **
17. Undercarriage check (general inspection) **
18. Water tank mounts (bolts holding secure) **

ON THE ROAD

The main objective travelling is to be able to enjoy relaxing holidays and weekends. However if you get worried or nervous about towing, you're not going to relax, so remember the golden rule: take it easy.

The first time you tow, we recommend spending an hour or so driving gently around quiet roads. A new sub-division with no traffic is ideal. Build your confidence & get comfortable by getting the feel of your Unit & how it feels to tow.

If you still lack confidence the Caravan Trade and Industries Association in your state may offer an introductory course for new owners. This includes tips for towing & useful advice on towing safely & confidently.

For more information check in the white pages or ask your local dealer.

The legal speed limit when towing varies from State to State but at speeds of around 80km/h your Unit will handle smoothly. Excessive speed with a camper trailer or caravan can be hazardous to both you & others on the road, so we always recommend taking it easy.

Safe driving involves keeping to the left, avoiding pot holes and rough edges and allowing others to pass when the road is wide enough. Sudden or violent swerving is extremely dangerous, it is better to ease your Unit out of the rough and avoid loss of control.

When towing in a manual vehicle, you will use your gears a lot more than normal driving situations. Always start in first gear and let the clutch out slowly. Do not try to start the vehicle on the second gear even when on a downhill slope. Don't ride the clutch excessively and never be in a hurry to change up to the next gear. Take each gear shift gently and allow the revs to build up before shifting.

With automatic vehicles, refrain from using the overdrive gear. When driving downhill, use the gears in conjunction with your brakes. A good driver will change to a lower gear in plenty of time, using this to steady the vehicle.

Extra consideration is required when driving in wet conditions involving longer braking distances, more cautious starts & slower turning speeds.

TURNING & OVERTAKING

Having trained yourself to relax, don't forget you're towing several metres of camper trailer or caravan behind, and this means a different approach to overtaking. **Remember that the Units wheels don't exactly follow the car wheels, they cut corners slightly. You must make allowances for this.**

Because the Unit will take a smaller but sharper curve than the car, always allow a bit more length than you need when pulling back into the left after overtaking. When you're passing cyclists, remember they will be unaware that you have a caravan or camper trailer behind and may swing outwards slightly when your car has passed. Give them plenty of room.

As your Unit is wider than your car, you must allow for this when overtaking or pulling to the side of the road or entering gateways. It is useful to know just how much extra room you need. When turning corners travel further forward in a straight line before you turn, in order to give your Unit plenty of room to negotiate the corner too.

OFF ROAD DRIVING

Towing your Lumberjack Unit off road adds many new responsibilities on the driver. To drive safely when in harsher environments a level of common sense is required, if you do not think your Unit can handle the environment you want to go in go with your intuition.

Lumberjack Units are not designed for use on four wheel drive only tracks and should not be used on such tracks.

In harsh off road environments, it is to be expected that damages may occur to the Unit or towing vehicle which are accidental and sometimes unavoidable.

When traveling in remote areas always carry enough spare parts & supplies to cater for a 'Worst Case Scenario.' Always perform preventative maintenance and daily checks.

Minimum spare parts would consist of:

- Wheel Bearings
- Seals
- Wheel studs & Nuts
- Spare fuses

Please Note: When returning to main roads after being off road make sure to reinflate the tyres back to their correct pressures.

Wildlife

Australian outback roads are notorious for wandering stock & native wildlife which can be a danger to motorists. Due care must always be taken, and the possibility of an animal strike considered regarding speed & time of day you are driving. Most animals in the outback are more active at night which greatly increases the likelihood of an animal strike between dusk & dawn.

Towing a camper or caravan increases braking distance and has inherent risk associated with aggressive and defensive manoeuvring to avoid a collision.

Corrugations & rough road

Corrugations are arguably the most taxing & damaging road conditions to vehicles. Constant vibration can loosen vehicle components and adds stress to vehicles well in excess of normal road driving.

In these conditions take regular breaks to reduce driver fatigue & fatigue to your Unit.

When driving on rougher roads you need to take into consideration the fact you are towing a heavy Unit behind your vehicle & has added length to your setup.

Shock absorbers can become extremely hot on corrugated roads which can cause damage to seals resulting in shock absorbers fading (reduction in damping effect) and in extreme cases failure of the seal completely.

On rough and corrugated roads, it's important to adjust tyre pressures on your car and Lumberjack Unit to soften the effect and extend the contact patch of the tyre on the road. When driving in these conditions, it is strongly advised you carry a tyre pressure gauge/ deflator and a portable compressor to reinflate when back on the highway.

We highly recommend reducing your tyre pressures to the following when driving on corrugated terrain.

When traveling on corrugated roads it is highly advised to stop and take a break every hour to check the following parts on your Unit:

1. Tyres - Check pressure and condition
2. Wheel nuts
3. Lid latches firmly shut & pins in place
4. External component bolts (polyblock mount, stone guard, gas & jerry can holders)
5. Undercarriage check (general inspection, check for missing bolts)
6. Water tank mounts (bolts holding secure)

Corrugated roads also put a lot of strain on the batteries within your Unit. The vibrations in extreme cases can lead to dead cells which will severely hinder your batteries performance & result in a dramatically lower life span. They can also loosen the terminals which can mean a bad power connection & cause the power to cut out in the Unit.

If travelling on corrugated roads sit the batteries on a thick piece of rubber to lessen the vibrations caused by corrugated roads. This will not completely protect them but will lessen their impact.

Also ensure to check the wing nuts before you set up your Unit to ensure their connection is tight.

Sand

When driving on sand it is important to lower tyre pressure on both the vehicle and Lumberjack Unit. By lowering the pressure, you will effectively create a larger footprint for the tyre which will reduce how far it sinks in sand.

Sand shape & compaction will vary around the country, so it is necessary to reduce the tyre pressures. When driving in these conditions, it is strongly advised you carry a tyre pressure gauge/ deflator and a portable compressor to reinflate when back on the highway.

We highly recommend reducing your tyre pressures to the following when driving on sand terrain:

Please Note: Prolonged driving on sand will cause the tyres to heat up which will increase the pressure within the tyre. If driving in this environment stop every hour to allow the tyres to cool down before continuing.

Bulldust / Dust

This phenomenon is common on outback roads. Fine dust can settle in large pot holes obscuring them from unsuspecting drivers. It is important to reduce speed in these conditions and drive carefully to avoid the possibility of damage or an accident. It is impossible to prevent bulldust from getting into your Unit.

One of the best ways to prevent bulldust from penetrating the seals on your Unit is to apply a thin amount of Vaseline to the main seals on the body & toolbox of the Unit to catch the dust before it can enter. If this practice is used please remember to clean it away before storing your trailer.

Please Note: Lumberjack Units are not dust proof. Any resulting damage from traveling on his terrain is not covered by the Warranty.

Causeways

Outback roads often have causeways to control water runoff & prevent erosion of the road. When traveling at speed these causeways can be a danger to motorists and vehicles so due care should be taken to reduce speed when approaching them. In very remote areas these often won't have signposts so special care should be taken in these areas.

Creek & River Crossings

These crossings can be extremely dangerous even in low water levels and should never be attempted in times of even mild flooding. Towing a camper or caravan greatly elevates the risk in this situation and should never be attempted unless you are completely assured it is safe to do so.

If there is any doubt about access in flood prone areas, you should contact the local authorities to find out conditions and dangers before you proceed.

Please Note: Lumberjack Units are not waterproof. Any resulting damage due to river crossings is not covered by the Warranty.

CONNECTION PLUGS

Trailer Plug

It can prove quite useful to understand how your trailer plug works, knowing what each point does can assist in problem solving should one of the elements stop working for some reason.

Below is a diagram to explain what the connection points on the common trailer plug (7 pin flat plug) are.

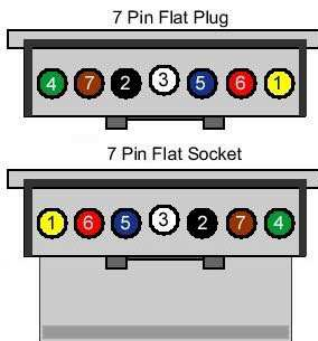

PIN #	CIRCUIT	COLOUR
1	Left-hand turn	Yellow
2	Reversing lights	Black
3	Earth return	White
4	Right-hand turn	Green
5	Servicing brakes	Blue
6	Stop lights	Red
7	Rear lamps, clearance & side marker lamps	Brown

Anderson Plug

All our Units are fitted with an Anderson plug at the front of the drawbar & inside the front toolbox (Camper Trailers & Caravans) at the fridge slide for charging the battery as you are towing & running a portable fridge. Having a working Anderson plug on your towing vehicle is essential.

Anderson plugs are sturdy but not indestructible and as such must be treated with due care. At all costs avoid letting it sit where it can get crushed or exposed to dirt and water as these can damage the connection points & prevent it from working.

Before going on a trip be sure to visually check the connection points for any signs of deterioration, should the points be in bad condition, replacements can be purchased from most vehicle accessory stores. If further damage has been sustained to the plug replacements for the plug head can also be purchased at most vehicle accessory stores, if unsure about replacing these, see an auto electrician.

When in storage you can protect the Anderson connections using dust covers, these can be purchased at a low cost from vehicle accessory stores.

If by some accident dirt or debris gets caught in your Anderson plug, use air to try and dislodge it, (e.g. small keyboard cleaning tools or air compressor on low settings).

If dirt or debris cannot be removed the head piece will need to be replaced.

Please Note: DO NOT USE SHARP OBJECTS to dislodge anything in the Anderson connection points.

RECOVERING YOUR UNIT

All Lumberjack Units are fitted with recovery points at the rear which can be used to safely move your Unit. When using these points, you **MUST** use a bridle style strap before attaching a regular towing strap to that. This helps to ensure no excess strain is put on one recovery point over the other and evenly distributes the weight of the camper.

Only winch or straight tow the Unit to recover it.

If using a tow strap, check the strap and its packaging for the Minimum Breaking Strength (MBS).

It is recommended that the minimum breaking strength of the strap should be between 2 and 3 times the vehicle's gross vehicle mass (GVM) and the strap must be suited to the GVM of the lighter of the vehicle & Unit in the recovery process. When recovering the Unit ensure a safe distance is kept at all times & no passengers are in or on the Units. Carefully read all warning labels present on the equipment used during the recovery.

Please Note: A heavy blanket must be draped over the strap during use to reduce any unintentional rebound of the strap.

IMPORTANT NOTES:

1. **DO NOT** use a snatch strap. The extreme kinetic energies may cause failure of the recovery points resulting in **DEATH** or **SERIOUS INJURY** as well as damages to the Unit & vehicle.
2. **NEVER** attempt a recovery without the proper equipment.
3. **NEVER** stand between the vehicle & Unit during a recovery
4. **NEVER** attach a recovery strap to a vehicles tow ball.

REVERSING

Many owners still adopt the technique of unhitching their Unit and pushing it around by hand in a tight spot using its jockey wheel. This is time consuming and not much fun in poor weather. Backing is quite a simple technique. All you need to do is turn the car wheels in the opposite direction you would if the car was on its own. This will push the Unit in the desired direction. It may take a little time to get used to this, but we encourage you to practise if you can to build confidence.

If you are still experiencing difficulties, try placing your hand at the bottom of the steering wheel (in the 6 o'clock position) Then turn the wheel in the direction you want the Unit to go left (clockwise) or right (anti-clock wise). Begin straightening the wheel just before the Unit reaches the full reversing position you require.

If you over-steer when practicing and reach too sharp an angle with the Unit, pull forward and straighten up, then start again. You will find this much easier than trying to correct with opposite lock.

Practice your turns in a wide open space at first (a large empty car park is ideal), you'll soon get used to it. The longer the Unit the easier it is.

SAFETY DURING AND EMERGENCY STOP

Please carry a warning device, i.e. Reflective Triangle, to be displayed when necessary.

Pull off the road as far as possible when changing a tyre, or in other emergency situations, remembering your Unit is larger than the tow vehicle.

It is advisable that everyone leaves the car and stays well clear when it is parked on the edge of a road or highway.

BAD WEATHER

While camping you may encounter bad weather, if bad weather is forecast take down the annex completely & pack it away to avoid any damages, weather damage is not covered by Lumberjack's warranty.

SECURING YOUR UNIT

Once the perfect location has been found, it is highly recommended to use suitable wheel chocks to help secure the Unit & prevent it from moving in the event of any brake failure. Wheel clamps or chocks can both deliver this security & can be found at most vehicle goods stores.

Below are some tips regarding the security of your Unit.

Protecting Valuables

When not at your campsite the best place to keep any valuable items is in your vehicle completely out of sight. Most vehicles are completely enclosed Units which makes them the safest place for anything valuable to be stored. If desired, a small safe can be kept in the boot of the car for any highly valuable items.

Remember:

- *If keeping anything in your car, make sure it is locked each night before you go to sleep!*
- *The best way to keep valuables safe is to leave them at home.*

Knowing your neighbours

When camping in a commercial location you may have various neighbours around you, not only is it courteous to say hello or have a brief chat, but it also assists to establish a camper comradery where you generally lookout for one another.

Just as you can keep an eye out for anything suspicious or anyone who doesn't seem to belong around their site, they can do the same for you.

Camping is a fun experience outdoors & it never hurts to help a fellow camper out when we can.

D. Set Up – Operation

SETTING UP - THE BASICS

1. Check site is level, free of ants nests, no dangerous branches or other overhead obstructions.
2. Position Unit to selected site.
3. Apply hand brake to Unit and place chocks under wheels.
4. Unplug both the trailer plug & the anderson plug from between your vehicle and Unit.
5. Undo safety chains.
6. Lower jockey wheel.
7. Lower corner stabilizer legs support the Unit. **DO NOT** use the stabilizer legs to raise the Lumberjack Unit level.
8. To erect your Unit, refer to the individual assembly guide further down this section of the manual.
9. Fill water tank if necessary or connect hose.
10. Connect electric power lead if 240v installed.
11. Turn on main power of camper.
12. Have a “cuppa” and relax.

Set Up Tips:

- Do not use a floor mat inside your unit, this can cause a moisture build up on the floor leading to warping or damages.

Levelling your Unit

When you have reached your destination you will need to level your Unit before opening & use. To do this use your jockey wheel to raise or lower the front of the Unit, you can use a small kitchen leveller inside the Unit to assist in getting it perfect.

Once the trailer is sitting level you can lower the stabiliser legs for support.

To do this pull on the side level & support the leg as it swings out. Then use the designated winder bar to lower it to the ground.

If you are camping on softer terrains, you may want to additionally use timber boards under the stabiliser feet for added support & to prevent sinking.

IMPORTANT NOTE: DO NOT support the Unit's whole weight on the stabiliser legs.

They are designed to only stabilise the Unit not hold it's weight.

The legs may collapse & the feet may break if you apply weight to them.

Kitchen Unit

Lighting the stove

1. Check the battery underneath the cooker is in good condition & not leaking. (If so please replace it)
2. To light the stove push down on the dial of the burner you wish to use, wait a moment then turn the dial to ignite & set the flame intensity.
3. To turn off the stove simply turn the dial to the off position & the flame will extinguish.

Please Note: Sunlight may reflect off the sink & cause canvas damage. To prevent this it is recommended that when not in use, either completely cover the kitchen slide Unit with non-reflective material or pack away the slide into the kitchen Unit cavity.

Main Control Panels

Each Lumberjack Unit is fitted with a main control panel inside the main cabin, below are diagrams and explanations of the different control panels Lumberjack Units have, what they mean & how to read them.

Main Internal Control Panel – Type 1

This is the main internal control panel for some of our older models of camper trailer. Not only can you gather useful information from it but as it is fitted with a 12v socket & 2 USB ports, it can also be used for charging various other devices.



Main Internal Control Panel – Type 2

This is the main internal control panel for the Mt Beauty. It is fitted with dials to display the tank levels, a volt ammeter, buttons to control the lighting, switches to operate the electrical components of the Unit & their fuses.

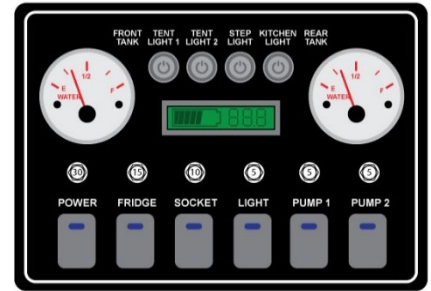

Main Internal Control Panel – Type 3 (Mt Beauty)

This is the main internal control panel for the Mt Beauty. It is fitted with dials to display the tank levels, a volt ammeter, switches to operate the electrical components of the Unit & their fuses.

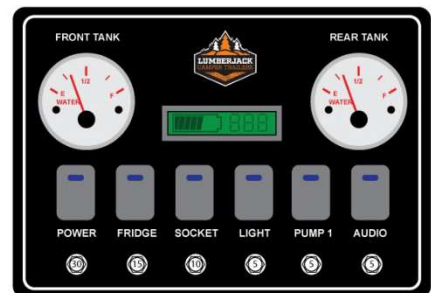

Main Internal Control Panel – Type 4 (Mt Buffalo)

This is the main internal control panel for the Mt Buffalo. It is fitted with the main power switch for the powered aspects of the Unit as well as dials to display the tank levels, a volt ammeter, switches to operate the electrical components of the Unit & their fuses.



Control Panel Components

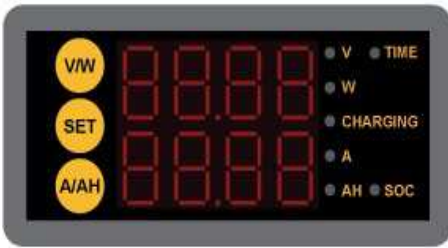

Volt Ammeter

This displays the current charge status of your batteries & the current voltage output of them. This helps you to keep track of how much power you are using.

Grey Style

To cycle through the settings on this meter press please use the buttons on the left.

The selected mode will be identified by a red light showing next to the corresponding function of the right options.

The top button will cycle between:

- V – Current Voltage of battery
- W – Current Watt status of battery
- Time – Clock function

The middle button is used for setting the time on the clock.

The lower button will cycle between:

- A – Amps being drawn from the battery
- AH – Amp hours left of current charge status
- SOC – State of charge %



Green Style

This display will automatically alternate between showing the current voltage of the batteries & the percentage of charge currently held by the batteries.

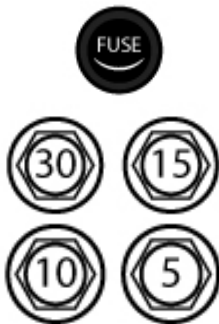

Examples of Fuses with various Amp ratings

Fuses

The fuses for control panels may be labelled "D1", "D2" & "D3".

Black Fuse

This fuse is for the control panel itself; this can be unscrewed in order to replace the small fuse inside it if the display panel stops working.

Numbered Fuses

The numbers on the fuse represents the amps that runs through it. Should an issue occur causing a short circuit the fuse will protrude from its slot. If this occurs press it back in carefully to reset it, if the fuse continuously protrudes from its slot there may be a further issue, refer to the fuses section of this maintenance guide.



12v Socket & USB ports

Sockets

This control panel comes with a 12v socket & two USB ports. These can be used for charging various devices such as phones or handheld games.

The USB ports have different amp power levels, meaning charging using the port running on 2.1A will be faster than the other.

The 12v port can be used the same as a normal vehicle one. It is not recommended to try and run a portable fridge from this socket as there is a dedicated one in the designated fridge slide.



KITCHEN WATER LEVEL



Water Tank level indicators

Tank Levels

To read how much water is sitting in your individual tanks your control panel will have either a dial or a light scale system. If the dial or light is on 'F' this means the tank is full. If the dial or light is on either 'E' or 'RES' it is empty.

Lighting Scale

The lighting scale system is as follows:

- 5 Blue Lights = Full tank
- 4 Blue Lights = 80% Full
- 3 Blue Lights = 60% Full
- 2 Blue Lights = 20% Full
- 1 Blue Light = 20% Full
- 1 Red Light = Below 10%



Various switches From Left (A, B, C & D)

Switches

There are various switches which may be on the control panel.

Switches A, B & D can only rock up or down & function as on or off.

Switches A & B will display a light when active.

Switch C is used for controlling an electric awning or similar fixture, this switch can rock up, down & sit in the middle. When in the middle position it is inactive. The up & down arrows indicate whether you want the awning to extend or retract.

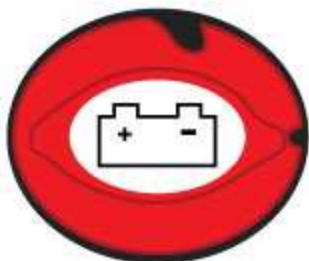

Isolator Switch which may be on main control panel

Isolator Switch

This is a main isolator switch, turning this on or off will cut all power to the unit. Nothing can be powered when the isolator switch has been set to off.

It can only be set as on or off.

Please Note: This Isolator switch design is unique as it is on the internal control panel, most switches are located near the batteries of the unit.



Push Buttons

Buttons

These buttons are used on some control panels to control the interior lights, pumps & sockets etc.

Simply press them in to activate & they will display a blue light.

ACTUATORS

How to use:

Opening

1. Using your remote or the fixed remote inside the camper trailer, hold down the designated button to open the front bed first.
2. Once the front bed has been completely opened, proceed to open the rear bed (if applicable) using the designated buttons.
3. Refer to your pole plan & Model User Guide for further instructions regarding the full set up process of the main cabin tent.

Actuator Control Panels

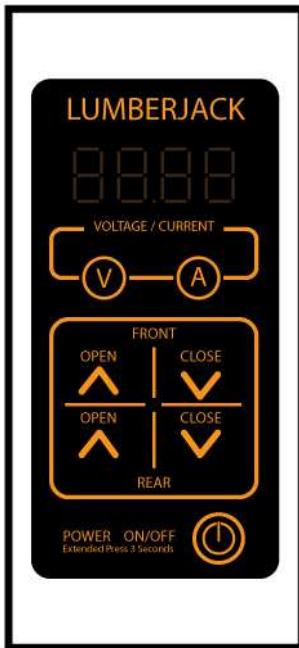

Glenaire Actuator Control Panel

Glenaire Actuator Control Panel

This is the control panel for the Glenaires actuator system. If the small hand remote is unavailable these controls can be used to open & close the trailer. This control unit is different from others due to the Glenaire having both its front and rear bed automatic.

How to use?

To operate this control panel, hold down the button for the action you wish to take place, on the digital display at the top it will show the Amps being current used through the actuators.

Upper Buttons

V – Current voltage of the batteries

A – Amps currently being drawn from the trailer

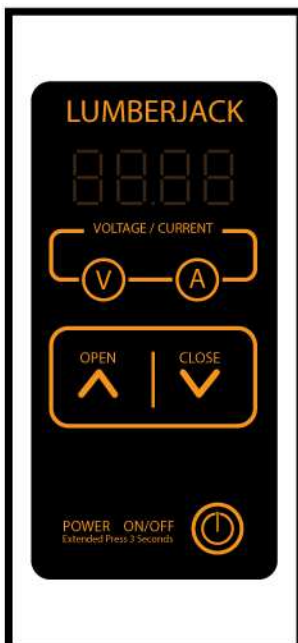

Actuator Control Panel

Actuator Control Panel

This is the control panel for the actuator system. If the small hand remote is unavailable these controls can be used to open & close the trailer.

How to use?

To operate this control panel, hold down the button for the action you wish to take place, on the digital display at the top it will show the Amps being current used through the actuators.

Upper Buttons

V – Current voltage of the batteries

A – Amps currently being drawn from the trailer

Actuator Remotes

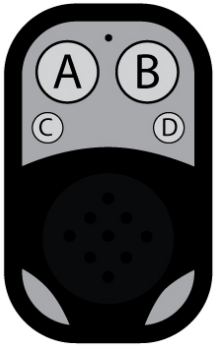

Remote Control – Type 1

How to use?

Before the remote can be used on the trailer it will need to be programmed if not already. If not yet programmed, please refer to the *How to program a Glenaire remote* guide.

What do the buttons mean?

A – Front Bed Open C – Rear Bed Open
B – Front Bed Close D – Rear Bed Close

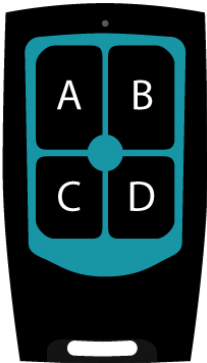

Remote Control – Type 2

How to use?

Before the remote can be used on the trailer it will need to be programmed if not already. If not yet programmed, please refer to the *How to program a Glenaire remote* guide.

What do the buttons mean?

A – Front Bed Open C – Rear Bed Open
B – Front Bed Close D – Rear Bed Close

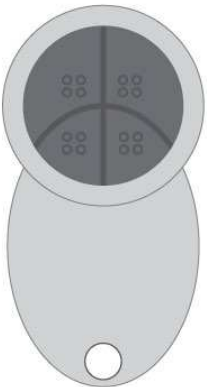

Remote Control – Type 3

How to use?

Before the remote can be used on the trailer it will need to be programmed if not already. If not yet programmed, please refer to the *How to program a Glenaire remote* guide.

What do the buttons mean?

Top Left – Front Bed Open Bottom Left – Rear Bed Open
Top Right – Front Bed Close Bottom Right – Rear Bed Close

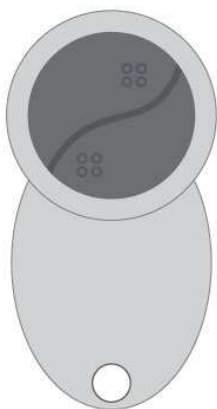

Remote Control – Type 4

Control – Type 4

This is one style of remote for the newest actuators.

How to use?

Before the remote can be used on the trailer it will need to be programmed if not already. If not yet programmed, please refer to the *How to program a Glenaire remote* guide.

What do the buttons mean?

Top – Open
Bottom – Close

E. Packing Down the Unit – Camper Trailers

Winch Closing

To close using the winch system please do the following:

1. Attach the rear winch.
2. Roll approx. 5m of black strap from the rear winch. Then using an annex pole as a tool, hook the winch hook over it and lift the black strap over the main tent & attach the hook to the same loop as the front winch on the lid.
3. Roll approx. 1m of black strap from the front drawbar winch.
4. Start tightening the rear winch to begin lifting the camper trailer lid, once the front winch becomes tight, go and release more strap from the front winch.
5. By switching back and forth between the front and rear winch, adjusting each as you go and tucking away any loose canvas, ensures the camper trailer will close safely.

IMPORTANT: Check to make sure the internal trailer hinges are free from canvas and fittings before completely closing the lid and that no canvas or cabin compartments are closed between the seals anywhere around the lid. (See example image below)

6. Once the lid is almost lying flat, carefully pull down on the lid & lock the lid down using the lid latches either side of the camper trailer. If you are unable to get the latches locked undo the latches from the lid & pull down the lid using the rear winch.

Please Note: Take careful notice of the compression of the seal around the camper lid during this step. Refer to the bearings & seals section of this manual for further information.

7. Remove the rear winch and stow away.



Example of Canvas being pinched in Lid

Please Note: Operate the winch ONLY use the manual lever to wind or unwind, DO NOT use any powered tools such as hand drills on the winch as this will void your warranty & cause damage. This practice is DANGEROUS & could cause serious injury.

Actuator Closing

To close using the actuator system please do the following:

1. Check all internal U-poles have been fully lowered & the internal table has been collapsed.
2. Using the remote provided hold down the designated button to begin the closing process, begin with the rear bed (if applicable) then the main bed. As the camper is closing take notice if it looks as though any of the U-poles are swinging out as this may prevent the camper from closing. If this occurs stop closing the trailer & push the U-pole flat against the bed then continue with the closing.
3. Once closed lock the lid in place using the lid latches either side of the camper trailer.
4. Turn off the isolator switch to prevent the batteries draining power unnecessarily.

IMPORTANT (ELECTRIC OPENING):

DO NOT FORCE YOUR TRAILER SHUT!

Do not try to manually push or pull your camper closed or open.

Force may damage the actuators and resulting damage will not be covered under Lumberjack warranty.

If you encounter a problem during the closing process please proceed to the troubleshooting section of this manual for further instructions.

F. Care & Maintenance

After taking ownership of your new Lumberjack Unit it is imperative to maintain it. This not only keeps it looking it's best but lengthens the life of the product, allowing you to enjoy it for a prolonged period. Just as motor vehicles require regular maintenance, our Lumberjack Units do also.

SECURING YOUR UNIT

When not in use it is imperative your Lumberjack Unit is secured & locked.

Not only does this mean anything stored in the Unit is safe but the Unit itself is safer from potential dangers.

To secure your Unit it is highly recommended to use wheel chocks or a wheel clamp during storage, this also assists as a backup should a handbrake failure occur. Ensure all your toolboxes are locked & the tanks themselves also.

High Tech Solutions

To secure your Unit using more high tech methods of security, GPS vehicle trackers are available which can be used to track your Unit live via your mobile phone in the event of an emergency.

If you are worried about battery usage, there are models which will only activate once the Unit is moved.

DIY/ Budget Solutions

For those looking for a more budget friendly security measure you can purchase a small battery operated trail camera fitted with infra-red sensors to your car or Bluetooth video feed which can be fitted to the front drawbar of the Unit hidden from site. These cameras can be set an angle where should the unthinkable happen you can get video of the perpetrator's registration.

A standard barn own pest deterrent can be fitted with motion sensors or alarms and placed on the front or rear of the camper to signal or deter threats.

Stainless steel armed cable locks are also available, these emit a 120 decibel alarm if cut which will immediately inform of any potential theft of your Unit.

To secure the tow block of your Unit a cable bike lock can be threaded through the tow block hole & locked, this prevents anyone from attaching the polyblock to a vehicle which would make taking the Unit very difficult.

Chains

It's an old technique but works quite effectively.

Chain can be used in a variety of ways to secure your Unit & also the items in it. Chain can be looped around the tyre and padlocked to create a makeshift wheel lock in emergency cases.

It can also be used to secure to secure camping equipment such as portable fridges, a thinner chain can be used & looped through multiple 'D Rings' on the fridge slide drawers & around the fridge handles then padlocked to secure it in your Unit. This technique can also be used for items such as generators, ice boxes or other similar items.

STABILISER LEGS

The stabiliser Legs will require greasing when they become stiff.

To grease them firstly remove the protective dust cover.

Then simply apply a pea sized amount of grease to the main gears visible, ensure to get the grease in in the teeth, spread it around a small amount to cover them well.

FUSES

You may have noticed the numbered buttons in various locations such as the actuator control panel or main internal control panel, these are fuses, should something happen to short them they will protrude from their slot, if this occurs simply push them back in gently.

If they continuously protrude from their slot after pushing them back in, there is a further issue, please first refer to the trouble shooting section of this manual, if this does not help with your issue, then please call our toll free number & select option 1 to speak with a sales team member to troubleshoot for further assistance in this situation.



Example of Fuses

CAMPER BODY MAINTENANCE

The following maintenance is required on the main body of the camper:

Lanolin Greasing/ Lubricating

This should be done each time you return home from your latest adventure. We advise a lanolin grease or metal lubricant be used.

The areas you need to apply this to are:

- Actuator Strut holders
- Toolbox locks (internal join point)
- Lid & door hinges
- Tie down points
- Stabilizer legs

Greasing

This should be done before you go away on a trip, the following parts to grease have specified grease points.

Swing arms

There are two points on each swing arm which need greasing.

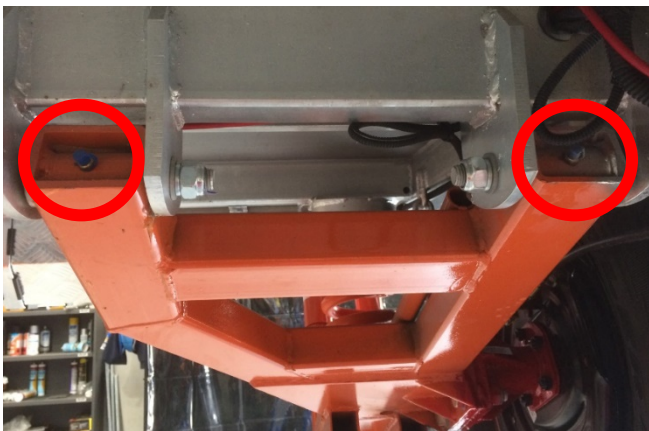

Hitch

There are two points on the hitch arm which need greasing.

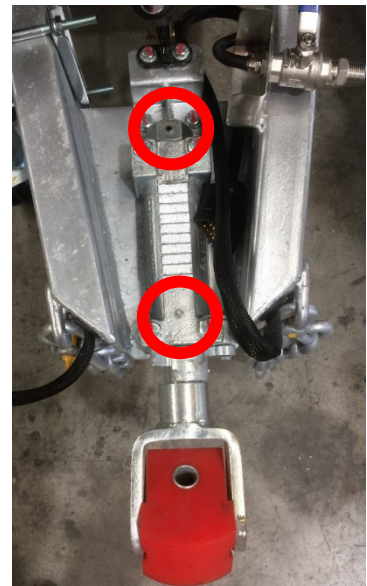

Paint

To best protect & maintain the paint work on your Unit is to clean it regularly. Please refer to the cleaning section of this manual for further information.

What to do if your paint has chipped?

We understand accidents can happen sometimes, if something does happen & the paint work on your Unit is damaged, we recommend applying a rust preventing lanolin spray or some touch up paint. These can be purchased from local hardware or auto stores.

Step 1.

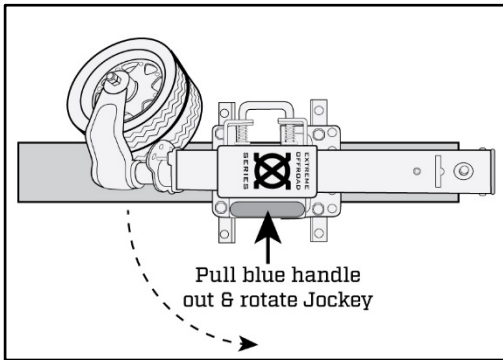

Step 2. (also Maintenance)

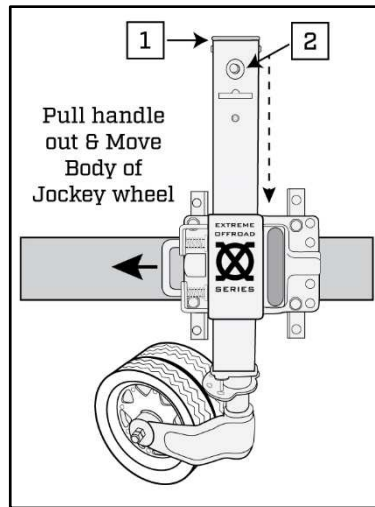

Step 3.

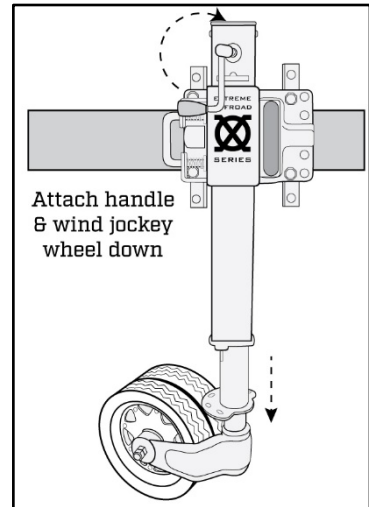

Maintenance

(refer to Step 2. Image)

Minimal maintenance is required to keep your jockey wheel looking new & in good working order. Protect the finish by keeping it clean and periodically applying a coating of silicon lubricant spray. Lubrication is needed if the jockey wheel ever feels rough or produces a grinding noise when cranked.

With weight off the jockey wheel remove the plastic cap [1] by removing the cap retaining screw. Place a sufficient amount of grease on the bevel gears, crank jockey wheel handle to ensure an even amount of grease is distributed on the bevel gears. Replace plastic cap [1] and insert cap retaining screw. Using a grease gun, fill a sufficient amount of grease into the inner shaft of the jockey wheel through the grease nipple [2] located behind the crank handle.

Crank the handle in a clockwise direction lowering the jockey wheel, this will distribute the grease and work the grease along the entire thread.

Please Note: If this jockey wheel is subjected to immersion in salt water or water crossings then maintenance should be carried out more regularly.

BE CAREFUL

Do not move Trailer if max winding mark is visible.

When manoeuvring your trailer with weight on the jockey wheel, keep the jockey wheel cranked to the lowest possible position to avoid bending or breaking the jockey wheel.

Locking Pin

When cranking the jockey wheel closed, ensure the locking pin secures in one of the locking points to prevent the wheel from spinning during movement & transport.

Handle Storage

When not in use or towing your trailer, remove the cranking handle & store in a safe location (e.g. Driver side door or vehicle glovebox etc.)

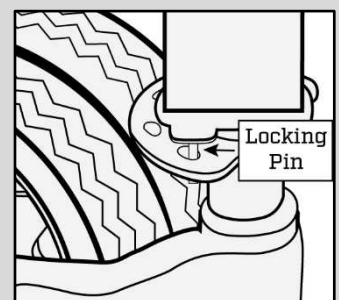
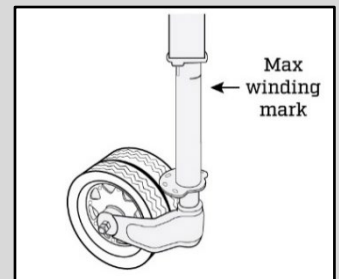

BREAK AWAY USER GUIDE

What is a break away switch?

Trailers that are over GTM 2000kg must have installed a break away switch. The switch is a wire that travels from the trailers brakes to the towing vehicle.

Why do I need one?

If the trailer becomes detached from the towing vehicle, the safety cable will pull out of the switch and engage the brakes on the trailer.

How do I secure the cable of the switch to my vehicle?

Break-Away Switch cable should be secured to the vehicle bumper or frame.

The cable can be attached many different ways. We recommend connecting the break away as illustrated below.

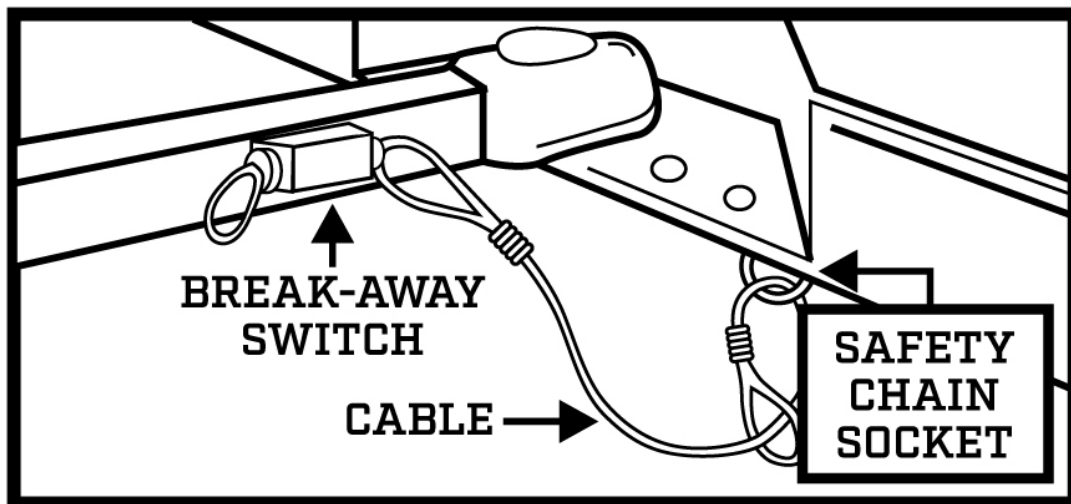

BE CAREFUL

DO NOT pull the Break Away cord from the unit to use as a hand brake rather than using the hand brake itself. When the cord is removed from the unit it draws power from the battery. If by accident the cord becomes removed from the unit, reconnect immediately and check your trailers battery charge level and charge if needed.

CARGO RACK USER GUIDE



Step 1.
Remove the pins from the two cargo rack arms.

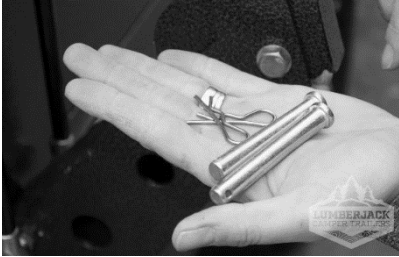

Step 2.
Store the pins in a safe place for use in Step 9.



Step 3.
Tie a rope or strap around the cargo rack frame, this rope will be used to hold the cargo rack as it is opened.



Step 4.
Remove **ONLY** the ring pins from Latches "A & B".
(At this stage **DO NOT** unhook the main latch.
The cargo rack will release and may cause damage or injury)

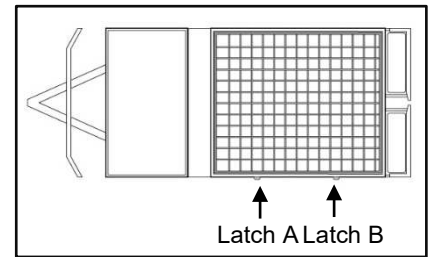

Step 5.
Completely unhook "Latch B".



Step 6.
Hold the cargo rack down with your right hand firmly while holding the rope or strap in the same hand.

Unhook "Latch A" slowly. Be careful to hold the rope securely as the cargo rack will spring open.



Step 7.
Use the rope to guide the cargo rack open slowly.



Step 8.
Once open leave the rope secured for use later when closing.

Step 9.
Using the pins removed in step 2.
Place them back in the arms while in the open position to stabilise the cargo rack.

(To close the cargo rack please follow the same process in reverse.)

Handy Tips:

- If the strap or rope is being blown around by wind thread the slack through the netting of the cargo rack to hold it back.
- When open you can use your cargo rack as a makeshift clothes rack for drying clothes, swimwear or wetsuits.

BE CAREFUL

- Hold rope securely when opening the cargo rack to prevent it springing open which can cause injury or damage to the trailer.
- It is highly recommended to remove all load from the cargo rack before opening to reduce strain & possible bending of the support arms.
- Do not overload the cargo rack, recommended max weight is 200Kg. Overloading the cargo rack can damage & apply unnecessary pressure on the gas struts.
- Forgetting to resecure the pins once the trailer is open can cause the cargo rack to overextend, this can pull & push the support arms against the trailer body causing damages as well as damaging the gas struts.

CHANGING WHEELS

Should something happen to your Unit requiring you to check underneath it or elevate it to change a tyre there is a specific way you must raise the Unit to ensure you are jacking it up safely & correctly.

Before jacking your Unit first make sure you are safely pulled over of off the road.

A regular car jack can be used on a Lumberjack Unit.

Before jacking up the Unit ensure the handbrake is active, then loose the wheel nuts a little bit using a wheel brace or 19mm socket on a breaker bar. This will make it easier to remove them once the wheel is off the ground.

Under the Unit you will notice the orange suspension arms & a large suspension springs. Place the wheel jack on the suspension arm under the large spring of the side you want to jack.

Once the jack is secure in position you can begin lifting the Unit, do not lift the Unit any higher than is required to remove the wheel. When in position it is recommended to lower the stabiliser legs, in the event of an emergency should the Unit come off the jack they can reduce any damage of the Unit dropping.

Loose & remove the wheel nuts with a wheel brace (Wheel brace) or a 19mm socket on breaker bar & keep them in a safe place. You can then remove the tyre & refit the spare. Once fitted ensure you tighten the nuts before raising the stabilizer legs and lowering the Unit.

Once on the ground again further tighten the wheel nuts before continuing on your trip.



Vehicle Jack in position on trailer

CHANGING WHEEL WARNING

- >> Do not get under a vehicle that is supported only by a jack – always use vehicle support stands.
- >> Use Jack only with correct engagement fittings.
- >> Never change a wheel on soft, uneven or sloping ground.
- >> Do not remove wheel nuts until the wheel is off the ground.
- >> Do not allow passengers in your Unit while it is on a jack.
- >> Before use – read the label attached to the jack carefully.
- >> After use – Ensure the flat tyre & jack are properly secured.

BEARINGS & SEALS

Wheel Bearings

Bearings must be inspected and lubricated periodically to ensure reliable, safe operation of your trailer. We recommend that your Unit be taken to Lumberjack Camper Trailers where correct wheel bearing service can be undertaken. The wheel bearings on your lumberjack Unit have the codes as follows:

SKF Branded

15123/15245 & 25580/25520

You will need both to complete the wheel bearing set, in addition to the wheel bearings you will need to replace the bearing seal. Please continue to the next section for details on them.

Wheel Bearing Seals

The wheel bearing seal on your lumberjack Unit have the code as follows:

225.337.50

Size: 85m Diameter & 56/57mm Inner diameter

Seals

The rubber seals on your camper need maintenance to keep them soft & prevent them from cracking or becoming brittle. If these seals are not taken care of, they will weather, crack & eventually lead to major water leaks. There are seals on all the toolbox doors & also the main lid. They are compression type seals similar to most automotive door seals.

When closing your camper please pay close attention to how much the seals are compressed, you want them to be compressed by just under 50% of their full width. This means you have made an adequate seal.

If you compress the seal too much you could damage it & cause splits. If the seal is too compressed simply loosen it as mentioned in the next section.

From time to time the latches or door locks may need adjusting to tighten these seals, to do this on the main exterior latches simply twist them tighter.

With the door locks use a spanner to tighten the bolt on the inside of the lock.

It is recommended to apply a silicon lubricant or spray (e.g. WD-40) to the seals once a month, this keeps the seals soft & less prone to cracking. It is also imperative to clear them of dirt or debris after a long trip as being in storage with dirt can damage the seals.

Simply wipe them down then apply a silicon lubricant before storage.

The locking mechanisms on the doors also need to be checked & tightened as required to prevent water from seeping through.

To tighten these locks first unlock & open the toolbox door, on the inside of the door you will see the back of the locking mechanism, tighten or loosen the small hex nut as required.

To check if it is tightened adequately close the toolbox door & lock it, you want the seal to feel snug but not so tight as to damage the rubber sealing. It may take a couple of adjustments to get it just right.

Please Note: We make every effort to protect our Lumberjack Units from water ingress by utilising rubber seals on all toolbox doors & latches as well as interior weather strips on the main lid. However these measures do not make the Unit waterproof. Any resulting damage from water ingress is not covered by the warranty.

Please refer to the General Storage section of this manual for more information on protecting your Unit from water & the elements.

WARNING! Do not close the lid if any canvas or internal fittings are outside or pressed between the seals.



Example of pinched canvas

BATTERY MAINTENANCE

Charging your batteries

Charging via Anderson connection

Whether your Unit has one or multiple batteries it can be charged the same way as the batteries are connected in a parallel circuit, this means you only need to connect the provided charger to the front Anderson plug in order to charge all the batteries in the Unit, if your charger does not have an Anderson connection you can have an auto electrician change this connection to Anderson for you or proceed with charging via the next method.

It is ideal to have your batteries on constant charge with a charger which has a shut off function to recognise when the batteries are full & prevent over charging.

Charging via alligator clips

You can directly charge the batteries not using the Anderson connection if your charger is fitted with alligator clamps.

To do this simply connect the alligator clamps to the battery & connect your charger to a power source. If your Unit has a multi battery system it is highly recommended to attach the positive alligator clip to one battery & the negative to another, this assists with the charge flow.

We highly recommend taking this charger to an auto electrician to have the alligator clips converted to an Anderson connection as this is the best connection for charging.

IMPORTANT NOTES:

- When charging your batteries you **MUST** charge them fully every time they are put on charge. Keeping them on charge for small amounts of time & not charging fully **WILL DAMAGE THEM**.
- When charging ensure they are kept connected for a **MINIMUM 24 hours**. Depending on the voltage status of the battery they could take up to **6 days** on constant charge to return to full charge status.
- The more batteries in your Unit the longer it will take to charge fully.
- Before turning on the power to your Unit **ALWAYS** check the terminal wing nuts are tight on the battery connections.

BATTERY STATE OF CHARGE	
Level	Voltage
100%	12.90V +
90%	12.75V
80%	12.50V
70%	12.30V
60%	12.15V
50%	12.05V
40%	11.95V
30%	11.81V
20%	11.66V
10%	11.51V
0%	10.50V

Charger Types

Having the right charger to suit your power needs is a vital part of battery care & prolonging their lifespan. Below is some more information regarding the charger supplied with your Unit (if one was supplied) & other kinds of chargers.

Standard Charger

If you were provided with a charger to go with your Unit, please note this is a max 10amp charger. It is designed to provide a multi-stage charging to your batteries.

If your batteries have fallen to a critically low voltage state (Below 10v) please contact Lumberjack for assistance regarding recharging them.

Care During storage

When your Lumberjack Unit is being stored it is imperative to take care of the batteries. If left for a long period of time sulphation will build up inside the battery & cause internal damage which could lead dead cells or total battery failure.

The ideal setup for storage is to have the batteries on constant charge with a charger which can identify when the batteries are at full charge & has a shut off feature to prevent over charging. However they will still need regular maintenance every 3 months.

If you do not own a charger of this kind, the batteries will need to be charged fully & maintained every 3 months to prevent damage & sulphation build up.

During the required maintenance please follow all of the points mentioned in the battery maintenance section of this manual.

Important Note: When charging allow the batteries to charge for a MINIMUM 24 hours. When charging batteries they MUST be charged fully each time. Failure to do so WILL damage the batteries.

Checking the battery state of charge

Most maintainable batteries (e.g. Century branded) have a water indicator on the top of the battery to give a quick on the spot diagnosis of the battery condition. This state indicator uses a colour key to identify whether it needs charging, replacing or is okay this code being as follows:

Green = Battery is Okay

Red = Replace the battery

Black = Recharge the battery

Please Note: On occasion this state of charge indicator can become stuck & may require a very gentle movement to loosen it to allow it to show its indication.

All Lumberjack Units are fitted with a volt ammeter which can be used to check the overall charge status of the Unit, this displays the voltage of all the batteries in the Unit joined in the circuit. If

the Unit is closed rendering this ammeter inaccessible, a voltmeter can be inserted into one of the external 12v sockets to check the overall volt status.

Please note this will only work if the isolator switch is set to on.

Checking individual battery charge state

To check an individual batteries state of charge you must disconnect it from the circuit. To do this firstly turn off the power via the main isolator switch, then undo one of the terminals on the battery & remove the wire connection.

After this, use a multimeter on each battery to check it's individual charge status. This can assist in checking if a battery has a dead cell. For further steps on how to identify a dead cell please go to the battery troubleshooting section of this manual.

External Maintenance

Caring for the exterior of the battery & keeping it in good condition means a longer life for the battery.

It is important to inspect the exterior of the battery as if left in bad condition it can have a negative effect on the performance of the battery's performance.

Dirt, dust or water can collect on the top of the battery and even cause an electrical pathway between the two terminals causing increased self-discharging and a possible build-up of sulphation.

The terminals must be cleaned regularly and free of any corrosion. If either terminal, including the nuts have been tampered with or show signs of corrosion they will need to be replaced.

If the corrosion is light this can be addressed with an acid neutraliser and water, then use a terminal brush.

Applying a terminal spray or thin coat of high pressure grease to the posts and cable connections can add protection against further or potential corrosion or oxidisation.

Regularly check around the battery compartment for stones or debris which could rub against the battery & cause holes leading to more serious issues.

Century Official Condition Check

Located on the front of the battery is a sticker with a check date on it.

You can have your battery checked at any Century shop location. They will then put a new sticker on the battery with a new date for the next check once done.

Why do batteries fail?

Batteries require more maintenance than most people would expect, they are not a simple 'set-&-forget' kind of thing. Below are some of the main reasons batteries may fail or reduce in performance:

- **Lack of Maintenance**
Neglecting to check the battery's general condition & cleanliness can build up to conditions affecting its performance & cause a potential risk.
- **Physical Damage**
Incorrect handling or rough treatment of the battery can lead to external damages & subsequent performance issues leading to their failure. Examples of this include using incorrect products to clean the terminals or accidentally dropping things on or hitting the batteries.
- **Undercharging**
Lead acid batteries need to be kept charged or at a very high charge level at all times. One of the leading causes of battery failure is undercharging, this can kill the cells within a battery preventing them from charging & subsequently causing their total failure.
- **Over Discharging**
Deeply discharging your batteries can severely damage them. They should not be dropped below their 50% capacity before recharging is required. A battery that has been discharged to 100% of its capacity regularly will be permanently damaged on an internal level and cannot be repaired.
- **Overcharging**
If you leave your batteries on a constant high voltage charge you can overcharge & damage the batteries. This can also cause the battery to gas which creates a terrible rotten egg smell which is highly toxic. Overcharging can happen due to forgetting to turn a charger off, incorrect settings or a faulty charger. If overcharged the batteries can also heat up and cause high temperatures which can also lead to internal damage.
- **Vibrations/ Corrugations**
As the batteries are fitted to a Unit which will be moving around a lot, they have been secured to the Unit to reduce vibration as best we can however, we cannot eliminate this variable altogether. It is recommended to avoid high corrugations as it can have an effect on the battery performance.
If you are planning to go on corrugated roads, we advise to place a large piece of rubber underneath the battery to somewhat reduce the vibration. This will not eliminate road vibrations, but it will help to lessen the effects.

Emergencies

If your battery does develop a leak DO NOT TOUCH IT. The liquid leaking from it is acid & as such is dangerous.

IMPORTANT: Battery acid can cause burns. Suitable hand, eye and face protection & protective clothing including chemical resistant gloves should always be worn when dealing with damaged batteries.

Battery Warranty (Century Branded Batteries)

If you have taken good care of your batteries but have still encountered an issue the best thing to do is firstly check if it is within 12 months of your handover, if so, you can contact Century Batteries directly to discuss the possibility of a replacement if they are proven as faulty due to them being under a 12 month warranty from the day of handover.

If you decide to contact them, you will need to provide your Lumberjack receipt as proof of purchase.

GAS BOTTLE AND REGULATOR

Handle your LPG bottles with care. When connecting or disconnecting your gas bottle, the connections are left-hand threads. Always have your gas cylinder valve closed when travelling or not in use.

Only have an authorised service agency make any adjustments to your regulator.

Before use it is highly advised to check for any gas leaks using the soapy water method. Simply mix a small amount of dish soap into some water causing as few bubbles as you can during this process & pour a small amount on the point where the hose connects to your gas bottle.

If any leaks are present, you will see the gas causing bubbles begin to form.

If this occurs turn off the gas bottle & check the connection point is secured & free of any debris, then reconnect & try the method again, if no bubbles are created the connection is sealed & ready for use.

If bubbles are formed again try the method again with a different gas bottle.

Gas Warning

If you smell gas –

1. Extinguish all open flames, pilot lights and smoking materials.
2. Keep bystanders away.
3. Do not touch electrical switches
4. Shut off the gas supply at the cylinder valve.
5. Open doors and other ventilating openings.
6. Leave the area until the odour clears.
7. Have the gas system checked and leakage source corrected by an authorised gas installer before using the system again.

WATER TANKS

General cleaning

It is highly recommended to use a bought tank cleaning fluid multiple times a year to ensure there is no build-up of residues or mould growth allowed inside the tank.

Caution: When in remote areas you may have to use water from untreated sources such as bore water or storm water, when using these water sources please note that it could have various residues in it which can damage the tanks if left for a prolonged period or cause mould growth within the tanks.

Mould

If you find that your tank has developed mould, immediately flush any water from it & use a store purchased specified tank cleaner on it as per its instructions.

Once the mould has been cleaned out use the red cordial method detailed in the trouble shooting section of this guide.

Storage

When your Unit is in storage it is recommended to store it with the water tanks full to maximum capacity, almost overflowing, by doing this you can prevent mould growth as there will be no air space left in which mould can grow.

After removing your Unit from storage, it is imperative to empty & flush out the tanks completely before filling with water you intend to use on your camping trip.

AIR CONDITIONERS

All manufacturers provide operating instructions with their product and it is recommended that these be read carefully to ensure correct operation. Also, complete and return your Warranty Card/Certificate as this will assist you should a problem occur at a later date.

Your air conditioner is covered by the air conditioner manufacturer's own warranty. Please contact the following:

>> Dometic ph.: (03) 9545 5655

BRAKE ADJUSTMENT

The brakes fitted are adjusted prior to supply. A brake clean and adjustment should be carried out between the first 300 to 1000 kilometres and then at the service intervals recommended within this document.

Brake Linings

Periodic inspection for lining wear or contamination from oil or grease should be undertaken by Lumberjack.

Wheel Nuts

Wheel nuts should be tightened to the 125Nm (90ft.lb) torque. Always use a quality torque wrench to check wheel nut torques. It is highly recommended to check the wheel nuts are sufficiently tightened while travelling on long trips, these can be checked multiple times a day, especially in cases when you may be traveling off road.

Handbrake Adjustment

If the handbrake on your Unit seems to not be stopping it as well as it used to, or it feels too loose you can adjust it by doing the following:

1. At the handbrake, push back the black protective sleeve.
2. Use a spanner to loosen off the nut on the handbrake.
3. Turn the main bolt clockwise to tighten it.
4. Test the handbrake to see if it has been tightened enough, if not turn the bolt more.
5. Use a spanner again to secure the bolt in place.
6. Slide the black sleeve back over the bolt.



Left image showing protective sleeve & right image showing sleeve removed.

240v ELECTRICAL SYSTEM

Optional: The 240 V electrical

Once your 240v system has been installed & signed off by an authorised electrician, the system itself does not generally need checking or maintenance. If you wish to have the system checked over for any reason, a qualified electrician can do this for you.

If you encounter any damaged wires please refer to the trouble shooting section of this manual for further instructions.

Leads

It is recommended to have any leads connecting your Unit to mains power tagged & tested as safe for use by a certified electrician on a yearly basis.

How to use:

You may need:

- 1 x 15amp power cable (length recommendation is 10m)
- 10 to 15amp adapter (if wanting to charge the batteries at home)

What do you receive?

- 240v 15amp inlet connection on the outside driver side of the main cabin. (Point "A")
- 1 x Double 10amp PowerPoint outlet connection inside the toolbox. (Point "B")
- (Camper trailers) 1 x Double 10amp PowerPoint outlet inside the trailer cabin. (Point "C")
- (Hybrid Caravans) 4 x Double PowerPoint Outlets (Points "C" through "F")

How do I use 240v?

1. Connect a 15amp power lead from mains to the inlet point "A". (Once power is connected points "B" to "F" are now live at 10amp.) (If not live the circuit breaker may need resetting)

How do I charge my batteries using the trailer's 240v?

1. Ensure your trailer has power by checking it is plugged in at point "A". Next use your battery charger with an Anderson connection, plug it into the Anderson Point inside the toolbox.
2. Plug the 240v connection of the charger into one of the sockets at point "B". This will now charge your trailer.

How do I charge my batteries when the trailer's 240v is not active?

Method 1. Connect the Anderson plug on your battery charger to one of the Anderson plugs on the trailer then connect it to a source of 240v power.

Please Note: charger needs to be edited to have Anderson connection for this method.

Method 2. Connect the alligator clips on your battery charger to your battery. (If a multi battery system place the positive alligator connection on one battery and the negative on a different battery. This assists with a better charge.

What if I am running my fridge from the toolbox Anderson plug?

You can use the Anderson plug at the front of the trailer to charge you batteries in the same methods as the toolbox connection.

Please Note: The power inlet point on your trailer a 15amp socket. If charging from home, you will need a 10amp to 15amp adapter.

Diagrams

Below are some diagrams referring to the above instructions, these also roughly depict the wiring patterns & circuit breaker locations for the corresponding models.

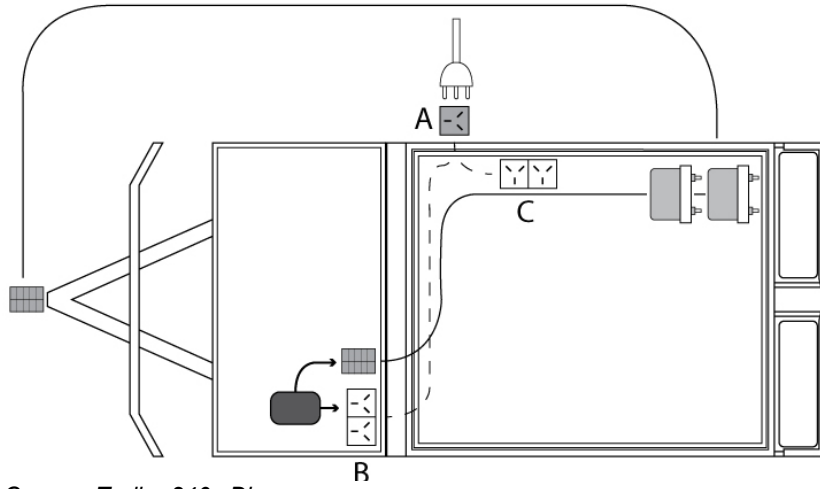

Camper Trailer 240v Diagram

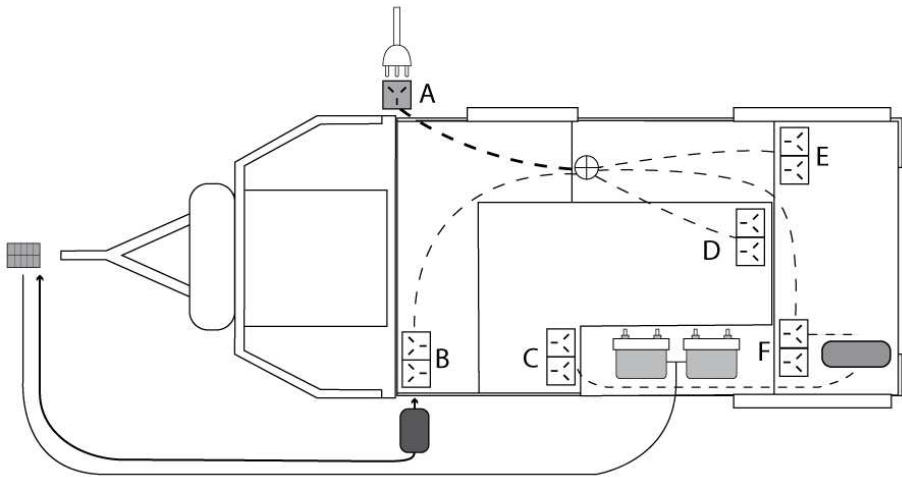

Mt Beauty 240v Diagram

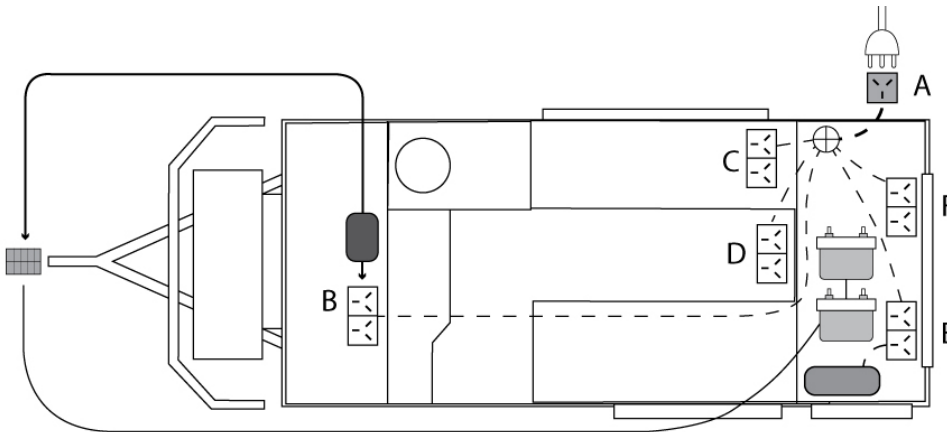

Mt Buffalo 240v Diagram

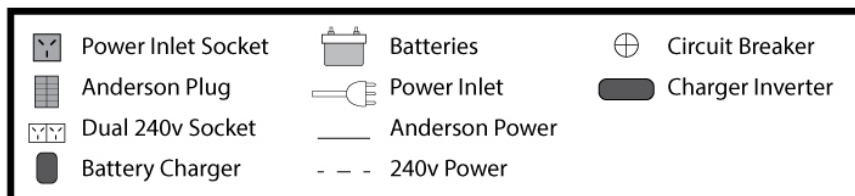

CANVAS

Tent

The tent is an important part of your Lumberjack Camper and is designed to withstand most situations, but you need to look after it to ensure that it lasts and continues to keep you and your family warm and dry when you need it to.

Seasoning

Before using your camper, you will need to 'season' it or precondition your camper canvas, for your tent to have its own natural water repellence.

1. Set it up in your backyard and remove the mattress. Be careful **not to over tighten and stretch the canvas or the stitching**.
2. Use a garden hose to completely soak the canvas. The camper tent must be wet down thoroughly to allow the fibres to swell and shrink to a tighter weave which closes up the stitching holes and further waterproofs the canvas.
3. This process of weathering will take 3 wetting and drying cycles.
4. Allow the canvas to completely dry between each cycle.
5. Determining factors are the amount of water allowed to soak into the canvas and the speed of the drying process from the sun.
6. Canvas fibres expand very slowly.
7. If you have any further leaks a wax stick can be rubbed on the stitching and zippers to improve the waterproofing.
8. When using the camper erect the tent in a manner that doesn't allow water to pool; yet not too tight to stretch the canvas or the stitching.
9. A combination of setting up on level ground, pole adjustment and installing all necessary ropes as this will help to achieve the best result.
10. **NEVER PUT YOUR UNIT AWAY IN STORAGE BEFORE OPENING IT AFTER EACH TRIP.** When you return from each trip open up your camper to air dry it.

Storage Tips

1. Ensure the canvas is thoroughly dry before packing away. Most fabrics are susceptible to mildew. Mildew results when the canvas is folded when wet or stored in a damp place.
2. Never store your camper covered with a tarp (unless it is tied up like a shelter) because it will impede airflow. Mould and mildew thrive on dirt, moisture and decreased airflow.
3. The best way for prevention of mould and mildew is to open it up at home as soon as possible to air dry. Whilst in storage, open up your Unit at regular intervals to ensure mould and mildew has not formed in your closed Unit.
4. **Air dry only.** Never apply heat to fabrics. **NO DRYERS.**
5. Always store your tent clean and dry and it will serve you well.
6. Keep Your Camper Tent Pest Free, it is important to also make sure to give your Camper Tent a thorough vacuuming after every trip.
7. Store 1 or 2 moisture absorbing packs/ dehumidifiers in the Unit to assist in drawing away any residual water vapour.

CLEANING

Camper Trailer Body

When general cleaning of the main camper or Lumberjack Units' body is required this should be done ideally with soapy water & a sponge, soft brush or generic garden hose.

It is important to only use these tools as they won't scratch the paint or damage the stickers.

Avoid using any harsh chemical cleaners or corrosive chemicals as these will have a negative reaction with the body paint, aluminium & stickers used on the trailer body.

Tyre Rims

Cleaning the rims of your Unit can be done with warm soapy water, as they have a shine to them it is imperative to not use any sort of corrosive or abrasive cleaners as this will dull & scratch them.

Commercial rim cleaners & de-greasers can be purchased from a local automotive store which should also do the trick should something stronger be required.

CAUTION: DO NOT USE A HIGH PRESSURE WASHER, this will strip the paint & stickers from your Unit & cause other damages. If your Unit has any paint chips from rocks using a pressure washer will worsen these.

Aluminium

The aluminium checker plate on the outside of your camper should only be cleaned with warm soapy water. Never use abrasive materials or cutting compounds as this could seriously deteriorate the finish on the aluminium.

Build-up of road tar or bird droppings can be removed with a diluted solution of mineral turps. This should be applied only to the surface that needs cleaning and it should be immediately rinsed off with warm soapy water.

Canvas Care

1. One of the best ways to keep canvas looking good and to delay the need for deep or vigorous cleaning is to hose it off on a regular basis (i.e. monthly if used on long trips), with clean water. This simple method will help prevent dirt from becoming deeply imbedded in the canvas and remove the need for more severe cleaning. In most environments, a thorough cleaning will be needed every two to three years.
2. Do not apply soaps, detergents, cleaning fluids or insecticides. **Never use detergents or bleach** which could ruin the water repellence and strip the colour of the canvas.
3. Persistent mould or mildew growth should be treated with a purpose made mould & mildew remover. Water should be cold to lukewarm.

Canvas which has been cleaned extensively may require reproofing with a purpose made reproofing spray.

Mildew will not form on the awning material itself but may form on the dust allowed to accumulate on the canopy.

CAUTION: DO NOT USE CAUSTIC CLEANERS, MILDEW REMOVERS OR METAL CLEANERS ON FABRIC AS THEY CAN DESTROY COLOURS AND WILL NOT BE COVERED BY WARRANTY.

Metal surfaces should be cleaned with warm soapy solution and thoroughly rinsed.

NOTE: ALLOW CANOPY TO DRY COMPLETELY BEFORE ROLLING AWNING UP.

Awnings

The cleaning of vinyl material on rollout awnings should only be done with warm soapy water. Never use any strong detergent or mineral based cleaners to clean the vinyl on your awning as it could lead to discolouring. The aluminium supporting arms to the awning should not need greasing or oiling and when storing your awning away for any period the awning should be completely and thoroughly dry to avoid mildew build up on the vinyl surfaces. A quality vinyl cleaner will keep your vinyl awning looking like new. Follow the instructions on the container

Cushions & Mattresses

PVC/ PU Leather Covered

The cushions in your Lumberjack Unit are PVC covered & cannot be machine washed. To clean them only use soft cleaning equipment such as sponges, dish cloths & soft bristled brushes.

Using abrasive cleaning products will damage or scratch the seats.

If required, you can use a mild or weak mix of detergent in combination with soft cleaning equipment to remove any dirt.

The PVC seats are air dry only. Under no circumstances should the cushions be put in an electrical dryer system.

For serious stains specialised seat cleaners can be used, these can be purchased from most supermarkets.

Please Note: DO NOT use any kind of abrasive cleaner e.g. Bleach as this will break down the fibres in the PVC & drastically reduce the life of the cushions. Avoid using detergents or cleaners containing concentrated detergents, oils, waxes, solvents, acid bases or abrasive elements.

Fabric Covered cushions & Mattresses

Spot Cleaning

For spot cleaning of the seats use warm water & a sponge or dish cloth in a wiping motion to remove mild to light marks from the seat.

For more deep set marks a gentle detergent can be used in combination with warm water and a wiping motion as mentioned above. If these do not remove the mark or stain proceed to the full washing instructions as below.

Full Washing

Remove the cover from the cushion and place into a domestic washing machine, generic washing powder can be used.

Ensure your machine is set to a cold water wash & the zips on the cover are fully done up.

Once washed avoid letting the cover dry in direct sunlight as this may lighten the fabric colour over time.

Ensure the cushion cover dries completely before putting it back on the cushion & returning it to your Lumberjack Unit.

Tip: To ensure the zips stay shut during the wash cycle you can use a safety pin threaded through the zip to the fabric to prevent it from coming undone during the wash cycle.

If using this process, please remember to remove the safety pin before returning the cover to your Lumberjack Unit.

Floors

The floors on your Lumberjack Unit are made from vinyl material or floating floorboards & need to be cleaned carefully as a result. To clean your floors only use soft cleaning equipment such as sponges, dish cloths or soft bristled brushes in combination with warm water & mild detergents.

When cleaning the floors use minimal water as the floor may warp if excessive water is used. If mopping is required dry mop only & allow the Lumberjack Unit to dry completely with the doors open before closing it up for storage.

Please Note: DO NOT use any kind of abrasive or strong cleaner as this can remove the protective coating on the vinyl leaving it susceptible to further damage or staining.

DO NOT use large quantities of water when cleaning the flooring as this will cause them to warp. Leaving moisture on the floor while in use or in storage may cause damage to the flooring. Ensure it is completely dry before closing up your unit.

Seating Base

The seating base is made from a wood laminate & can be cleaned using the same technique as the floors, please see the above paragraph.

Carpet (Exterior Drawers)

To clean the carpet inserts within the toolbox drawers firstly remove them from the drawers & brush off any surface dirt should there be any.

If washing is required to remove further dirt, a mild detergent can be used along with a hard bristled brush to scrub the carpet clean.

Before cleaning the whole carpet test your detergent on a small area of the corner to ensure the detergent you wish to use will not cause colour runoff.

Once scrubbed the carpet can be hosed down to remove any detergent residue. After cleaning ensure the carpet is left to fully dry before returning it to the Lumberjack Unit.

Kitchen Unit (Stainless Steel)

Microfibre cloth & mild detergent.

Use a small amount of mild detergent or non-abrasive cream cleanser and warm water on a microfibre cloth and use a circular motion at first to clean over the whole Unit.

After the initial clean go over it again with only warm water to remove any detergent residue, then wipe the whole Unit over with a dry cloth to dry the Unit.

During this last step wipe in the direction of the grain of the stainless steel, like wood, stainless steel has a grain, for the best finish wipe in the direction of this grain.

Specified stainless steel cleaners can also be used.

It is highly recommended to wipe down the kitchen Unit after each use, do not allow dirt or food residue to sit on the surface for prolonged periods of time as this can stain the steel.

Please Note: DO NOT use abrasive cleaners or scourers when cleaning as they can permanently scratch the surface.

Solar Panels (if applicable)

If your Unit has been fitted with built in solar panels, they may get dust or dirt on them & require cleaning.

Cleaning your solar panels regularly can improve their performance & longevity of service.

To clean your solar panels, firstly use a garden hose & water to remove the majority of residue which needs removing, a sponge or soft cleaning cloth can also be used. This alone should remove most dirt from them but if not, a light detergent can be utilised also.

Please Note: When cleaning the solar panels ensure the seal around their edges is not compromised (if integrated into the roofline), if water is used with them in this condition damage will occur. If the seal is compromised use a store purchased silicon to fill in the compromised area.

GENERAL STORAGE

It is highly recommended to store your Unit in a safe & secured location out of direct sunlight & protected from the elements (e.g. A shed or garage).

Exposure to the elements over a prolonged period during storage will wear the camper prematurely & can fade the paint work & stickers.

Every endeavour has been made to prevent water leaking into the Units, however the Units are not waterproof. If stored outdoors uncovered & exposed to the rain, leaking may occur. Damages caused by water ingress are not covered by Lumberjacks warranty.

Camper Covers

While in storage it is highly advised that a cover is used, as the Unit you have purchased is a valuable piece of your property it is imperative to take correct care of it & store it the right way when not in use.

Can I just use a plastic tarp to cover my Unit?

It is not recommended to use a tarp as a substitute for a purpose made camper trailer or caravan cover as they are not breathable. This can allow moisture to remain around the camper which can encourage mould & mildew growth as well as potential leaking into the Unit.

Using a tarp also means you may need ropes or bungees to secure it to your Unit, these themselves can rub against the Unit with the wind which could also cause various damages.

Storage Tips: Store 1 or 2 moisture absorbing packs/ dehumidifiers in the Unit to assist in drawing away any residual water vapour.

If keeping your Unit off site in storage remember to conduct regular maintenance!

IMPORTANT: When storing your Unit remember to turn off the isolator switch to reduce the voltage lost from the batteries, over time they will lose some voltage, this is normal.

While in storage the Unit will still need charging on occasion to recharge the batteries due to this normal small loss of voltage. Please see the Battery Maintenance section of this manual for more information.

G. SERVICING

Just as a car needs to be regularly services so does your Lumberjack Unit, these are not items to be left and ignored until required. There are some checks & smaller servicing items you can conduct yourself while on your travels or at home, but other items must be checked by a Lumberjack Servicing location or approved by Lumberjack servicing location.

Proper servicing is imperative to prolonging the life of your Unit & allowing you to enjoy many years of great camping trips. Please refer to the table below for further information.

Lumberjack Servicing Schedule

Item	Details	First 3 Months or 1000Km	12 Months or 10,000Km	24 Months or 20,000Km	36 Months or 20,000Km	Notes
Hitch	Inspect for damage, wear & lubricate	X	X	X	X	Check every 1000Km in off-road conditions
Handbrake	Check cables for damage and adjust when level extends beyond 3/4	X	X	X	X	Or as required
Jockey Wheel	Lubricate & check for stability and secure locking.		X	X	X	
Hand Winch & Webbing (Strap)	Lubricate winch & check webbing strap for any signs of damage.		X	X	X	Inspect webbing each use
Suspension Pivots & Bushes	Lubricate and check for excess movement		X	X	X	Lubricate every 500Km when experiencing water crossings or flooding
Brakes & linings	Remove drum and inspect lining thickness. Adjust brakes	X	X	X	X	Every 2500Km when in offroad conditions
Wheel bearings & seals	Inspect, clean and lubricate		X	X	X	Inspect every 2500Km when experiencing water crossings or flooding
Wheel Nuts	Check & tighten if required	X	X	X	X	Daily when traveling
Tyres	Check pressures & inspect for damages or punctures		X	X	X	Before every use
Lights	Check all lights are operating & no cables are damaged		X	X	X	Before every use
Batteries	Inspect terminals and test voltage & maintenance charge		X	X	X	Use maintenance charge or check charge levels daily
Gas System	Leak test using gas fuse		X	X	X	
Body Seals & latches	Check condition and flexibility as well as compression when closed. Adjust locks if necessary		X	X	X	Inspect for damage each pack up and adjust locks if necessary
General Fixings	Check all nuts & bolts ensuring none are loose, if loose tighten.	X	X	X	X	Inspect every 2500Km in offroad conditions

Further Note:

After 36 months continue to have all the items checked in 12 month time periods or as required.

H. Trouble Shooting

GAS

If your cooker does not light, there are a number of reasons that may have caused this, please review the following troubleshooting tips to solve this issue:

Problem	Possible Cause	Remedy
Cooker not igniting	Gas bottle empty	Fill or replace gas bottle
	Gas bottle not turned on	Turn on valve on gas bottle
	Gas hose on cooker not connected	Check bayonet is securely connected into receiver
	Regulator blocked	Check regulator is not blocked with dirt or debris.
	Kinked or damaged Hose	Check hose is not twisted or kinked, if so straighten out. If badly kinked or damaged it will need to be replaced.
	Ignition battery run out	Check the battery under the cooker has charge or has no leaked. If so, replace.
	Gas connection is poor	Use the soapy water technique to ensure there are no gas leaks, if so detach & reattach the hose, using the soap technique to check there are no leaks.
	Dirty stove components	Remove the grate, burner cap & burner head and clean out any food scraps or residue, clean parts if required then reassemble.
	Wok burner not igniting	Clean around the jet & check the burner head placement. Windy weather will hinder this jet from igniting.

WATER TANKS

If you are experiencing problems with your water tanks & pumps there are a number of reasons that may have caused this, please review the following troubleshooting tips to solve the potential issues:

Problem	Possible Cause	Remedy
Pump not working	No Power from control panel	Check circuit breaker & turn on isolator switch if no power is on.
	Flat battery	Charge or replace battery
	Faulty pressure switch	Replace pump, contact dealer for further instruction or replacement
	Bad electrical connection	Check connections with a multimeter or test light
Pump working but no water flow	Airlock in waterlines	Turn on the tap and hold a finger over the nozzle for 5 seconds and release. Repeat several times.
	Airlock in waterlines	Turn on the tap and let it run until the waterflow becomes steady. (The tap may sputter)
	Water Tank is empty	Fill water tank
	Kinked Hose	Check the hose for any signs of kinking or abnormal bending. If so, replace with a new hose.
	Damaged / worn pump diaphragm	Check hoses ensuring none are fouled

What to do if the water from your tank has a strange taste?

Solution 1: Flush any old water from your tanks & use a commercial tank cleaner according to its instructions.

Solution 2: Fill your tanks to half full, then pour in one 2L bottle of red cordial, let this sit for an hour or so then drain the tank. Refill then drain the tank again until no colour can be seen in the water from the cordial.

ELECTRICAL

There are some simple things you can check if there seems to be problem with your electrical system. Please follow the tips below to try and resolve some common issues.

Please Note: It is dangerous to be handling any bare wires with power flowing through them. Use extreme caution when checking & working with electrical systems. If checking wiring for frays, ensure the Isolator switch is set to off position.

Problem	Possible Cause	Remedy
No 12v Power	Main isolator switch is off	Turn on main isolator
	Flat Battery	Charge batteries according to instructions
	Faulty Battery	Check battery using steps in the next section 'Batteries'
	Main circuit breaker has tripped	Reset the main circuit breaker (this can be located next to the isolator switch on most models)
	Loose Battery terminals	Tighten the terminals with the power off
	Damaged Wiring	Conduct quick inspection (Repair/ replace – is this safe & how to do)
Lights not working	Tripped circuit breaker	Reset the main circuit breaker
	Poor connection	Check the wiring along the lights for damages. If damaged, turn main isolator off. Then wrap electrical tape around only the damaged wire as a temporary solution. Then contact LJ for further instruction.
	Circuit switch off	Check control panel & if off switch on
Tail lights not working (Parking & signal lights)	Poor connection to vehicle	Check the plug on both the Unit & vehicle for damage or debris
Circuit breaker tripping during use	Overloading the system	Check the power being drawn from the system & appliances, reduce number of appliances being used.
Appliance Not working	Faulty appliance or cable	Check the appliance & cables
	Main isolator switch is off	Turn on main isolator
Exposed Wiring	Cables getting snagged when closing camper	Turn main isolator off & disconnect from mains power. Then wrap electrical tape around only the damaged wire as a temporary solution. Then contact LJ for further instruction.
	Wire overheating through cover	Turn main isolator off & disconnect from mains power. Then wrap electrical tape around only the damaged wire as a temporary solution. Then contact LJ for further instruction.

BE CAREFUL

If either bed does not close DO NOT winch or force it to close without disconnecting the actuator first.

Should something happen & your actuators stop working the likely cause of this is insufficient battery voltage. This can be caused by excessive battery usage or failure to sufficiently charge them. The actuators will not operate if the battery voltage is below 12.7v.

To avoid this, immediately put the batteries on charge, if you are off the grid, this can be done by connecting your charger to a generator or connecting the anderson to your vehicle with it's engine running to charge the batteries. Then attempt to close the trailer, while connected to the running generator or vehicle. If this does not assist in closing the trailer refer to the following steps on how to remove the actuator.

Removing or disconnecting an actuator

In the event you need to remove or disconnect your trailer's actuator please follow these instructions:

Tools Required

- 6mm Allen Key
- 17mm Ring or open ended spanner or shifter
- Wire Cutters
- Electrical Tape

How To

1. Go to the storage compartment where the actuator is housed. At the bottom of the unit you will see an "R" shaped pin remove this & store in a safe place.
2. Remove the silver pin the "R" pin was holding secure.
3. There may be some pressure on this silver pin preventing it from coming out. If this happens please see the tip below these instructions for a tip on how to loosed this pressure.

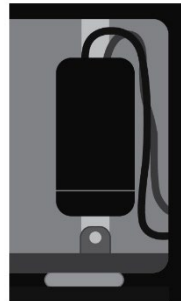

4. Now go to the top of the actuator & use your Allen key on the inside pin of the actuator & the spanner on the outside. Use these to undo the nylock nut & remember to store it in a safe location.

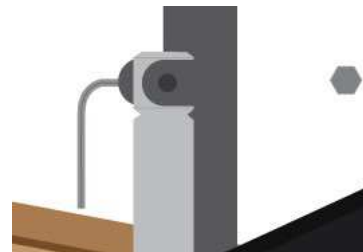

5. Use the Allen key again on the bolt to loosen this then remove it completely.

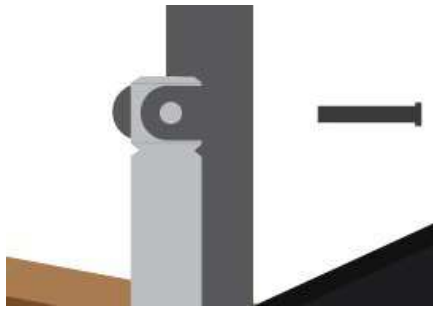

6. With the bolt removed carefully push the actuator towards the rear of the trailer.

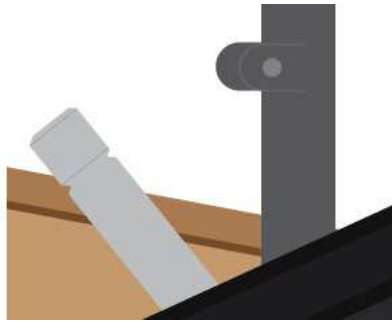

7. Now you will be able to close the main bed of the unit manually. During this closing ensure to watch the actuator so it does not hit anything during the closing process.
8. If you wish to remove the actuator completely from the unit you will need to go back to the storage compartment & check the main isolator switch is off, then cut all the wiring using wire cutters & electrical tape to secure the loose wire ends.

Tension Tip: If there is pressure on your actuator & the pins will not remove easily, release some of the tension by manually lifting the bed a little bit by loosening the front winch or tension strap at the front of the unit.

BATTERIES

Below are some problems commonly encounters and some methods to remedy them:

Problem	Possible Cause	Remedy
Battery Directly not charging	Faulty Battery	Check if anything on the charger is displaying any faults or errors. Then check the battery by following the steps detailed below.
	No mains power to charger	If no lights are displayed on the charger check the power to it has been turned on
	Faulty charger	Check to see if you can hear the internal fan & if lights are being displayed. Also see if the base voltage raises with the charger attached vs not attached. If no change occurs the charger may be faulty.
	Charger has overheated	Check if the charger is displaying any warning lights & if you can hear it running. Let it sit for an hour to cooldown before charging again.
	Loose Battery Connections	Check the wing nuts on the battery. Ensure that they are very tight.
	Time	The battery may not show signs of charging for a while after being connected to the charger. Have your batteries connected to your charger for a minimum of 24 hours.
Battery not charging from Anderson connection	Faulty plug connection	Confirm the plugs are firmly connected
	Damaged Anderson plug	Check the plug is clear from debris and pins are not damaged
Battery dropping power too quickly	Overloading power system	Ensure there is not an excessive amount of power being drawn from the system (e.g running fridge, charging multiple devices & running appliances at once.)
Battery Cracked or Warped	Overheating or overcharging	Immediately turn off your Unit & check for cracks or abnormal warping, if any is found immediately turn off the isolator switch to stop drawing power from it.
	Battery Fault	
Battery is emitting a rotten egg smell	Battery Fault	Immediately stop charging the battery & remove the charger, ventilate the area, extinguish any naked flames. The battery is dead & will need to be disposed of.

If you encounter further issues & the battery is Century branded, please call their contact number provided on the sticker on the battery itself for further advise & instructions.

If the battery is NOT Century branded, & if your Unit is within 12 months old contact Lumberjack for further advise. If advised to do so, dispose of the battery according to your local legislation.

Checking if a battery is faulty

If you suspect that one of your batteries has encountered an issue or is faulty you can test this by doing one of the following methods:

Method 2.

1. Turn everything off in the Unit & unplug any appliances or devices (e.g. fridges, phones etc.).
2. Check the digital display inside the Unit to see if it continues to drop voltage quickly. If so, this means that one of your batteries is not holding charge. The most likely cause of this is one of the cells in your deep cycle battery has failed.

Method 1.

1. Check the main isolator switch is set to the off position.
2. Disconnect the terminals from the battery you suspect is faulty.
3. Attach your provided charger to the battery & connect it to power.
4. Check the charger display to see if an error is showing or if the charger shows no signs of charging the battery. It may take up to 1 hour for the charger to begin showing signs of charging.
5. Keep it connected for a MINIMUM 24 hours UNLESS the charger shows a full charge state, you may disconnect the charger when it indicates the battery is fully charged.

Please Note: If the cell is dead it may not be able to charge to its full capacity. If this is the case your charger should pick up on this & shut itself off to prevent over charging if fitted with this function.

6. If the battery charges to full capacity record the voltage every hour after charging to see if there is a significant voltage drop. This can indicate a dead cell.

Please Note: If at any point you begin to notice a sulphurous smell coming from the battery immediately stop the charger, disconnect the power & extinguish any naked flames in the area.

This odour indicates dangerous levels of sulphation within the battery, it is no longer safe for use.

Dispose of the battery at your local authorised location & ventilate the area.

If the above methods do not provide your answer, please call Century for further troubleshooting assistance.

K. CONCLUSION

Again, we would like to congratulate on your new Lumberjack Unit, we are happy to have you as part of our Lumberjack family & are excited for your many adventures ahead.

We want you to have the best experience with your Unit & be able to operate it confidently, correctly & safely.

We know the information you have just reviewed can be a lot to take in, but we cannot stress enough the importance of understanding & taking it in. This information can help you keep your Unit in tip top condition for years to come.

If you have any further questions on the information contained within this manual feel free to give us a call on 1300 30 40 45.

Happy Camping!