

LUMBERJACK CAMPER TRAILERS

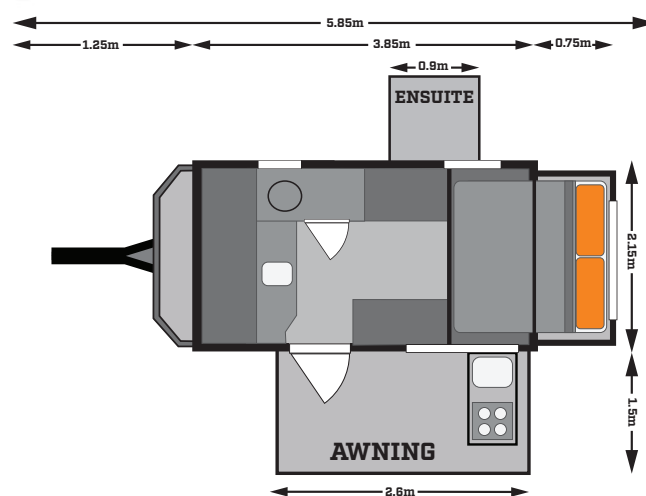

MT BEAUTY Classic



SPECIFICATIONS

13 Foot Hybrid Caravan

Size closed [L] 5.6m [W] 2.15m [H] 3.05m

Off Road Hybrid Caravan

Tare 2000kg* Ball Weight 160kg*

Drawbar Tube Size 150mm x 50mm x 4mm Hot Dip Galvanised

16" Mud Terrain Tyres with Alloy Rims Plus 2 Spares

Independent Coil Suspension & Dual Shockers

12" Electric Brakes with Breakaway

Swing Up Jockey Wheel

Kitchen

Stainless Steel Cooktop with Lighting, Sink, Cutlery & Utility Drawer

80L & 40L Water Tanks & 80L Grey Water Tank

2 x 9kg Gas Bottle Holder & 2 x 20L Jerry Can Holder

Power Supply

Anderson Plug Connection for Car

2 x 12V AGM Batteries with Level Indicators

7 x 12V Sockets 4 x Double 240v Sockets

Storage

Stereo System (CD, MP3, BT, SD, AUX & USB) with Dual speakers

3 x External Storage Compartments Including Dedicated Fridge Slide

12 x Internal Storage Compartments Including Under Bed Storage

Body

Hot Water System For Both Internal & External Shower Outlets

External Shower/ ensuite tent included

Electric Awning, Solar Panels & Air Conditioner Included

Gloss Interior Furnishings

4 x Internal LED Lights plus 5 x External LED Lights

Fold Out Queen Bed